

### Traffic Signs Authorisation

The Department for Regional Development(a), in exercise of the powers conferred by Article 28(2) of the Road Traffic Regulation (Northern Ireland) Order 1997(b) and now exercisable by it(c), hereby gives the following authorisation.

#### *Interpretation*

1. In this authorisation—

“the 1997 Regulations” means the Traffic Signs Regulations (Northern Ireland) 1997(d);

“20 mph speed limit zone” and “retroreflecting material” have the meanings assigned to those terms by regulation 2 of the 1997 Regulations; and

“road marking” means the road marking shown in the diagrams in the Schedule.

#### *Control of traffic by road marking*

2.—(1) The road marking is authorised for use for the purpose of the control of traffic and with respect to the use of vehicles on roads.

(2) The road marking shall be placed on a road in conjunction with the sign shown in diagram 670 in Schedule 2 to the 1997 Regulations when placed to indicate the point at which a speed limit begins or as a repeater sign, except where the road marking is placed within a 20 mph speed limit zone.

(3) The maximum speed limit indicated by the road marking shall be that specified in or under the diagrams.

#### *Marking to be of the size, colour and type shown in the diagrams*

3.—(1) Subject to the provisions of this authorisation, a road marking for conveying to traffic on roads a maximum speed limit shall be of the size, colour and type shown in the diagrams.

(2) Dimensions indicated on the diagrams in the Schedule are expressed in millimetres.

#### *Variations of dimensions*

4. Any dimension specified in a diagram in the Schedule may be varied in accordance with the following Table, subject to the Note to that Table.

---

(a) S.I. 1999/283 (N.I. 1) Article 3(1)

(b) S.I. 1997/276 (N.I. 2)

(c) S.R. 1999 No. 481 Article 6(d) and Schedule 4 Part IV

(d) S.R. 1997 No. 386

**TABLE**  
**Dimensions of road markings**

<i>Item</i> (1)	<i>Dimensions shown in diagrams</i> (2)	<i>Permitted variations</i> (3)
1	3 metres or more	(i) Up to 15% of the dimension where the varied dimension is greater than the specified dimension; or  (ii) Up to 10% of the dimension where the varied dimension is less than the specified dimension.
2	300 millimetres or more, but less than 3 metres	(i) Up to 20% of the dimension where the varied dimension is greater than the specified dimension; or  (ii) Up to 10% of the dimension where the varied dimension is less than the specified dimension.

Note: Where a dimension denoting the length or width of a road marking is varied in accordance with this Table, and there is a space between two parts of the marking, the dimensions of that space may be varied as required to accommodate the variation of the length or width of the marking, provided that the character of the marking is maintained.

*Proportion and form of numerals*

5. The numerals incorporated in the road marking shall have the proportions and form shown in Part VI of Schedule 13 to the 1997 Regulations.

*Permitted variants*

6.—(1) Where the circumstances in which the road marking is to be placed so require or where appropriate in those circumstances, the form of the marking shall or may be varied in the manner indicated below the diagrams.

(2) Where the form of the road marking is varied in accordance with this authorisation, the speed limit conveyed by the marking is varied to accord with the form of the marking as varied.

*Illumination of road marking*

7. The road marking shall be illuminated with retroreflecting material.

*Height of road marking*

8. The road marking shall not project above the surface of the adjacent carriageway more than 6 millimetres at any point.

*Revocation*

9. The Traffic Signs Authorisation made on 6th November 2002 is hereby revoked.

J. Carlisle  
Authorised Officer  
19 June 2003

## SCHEDULE

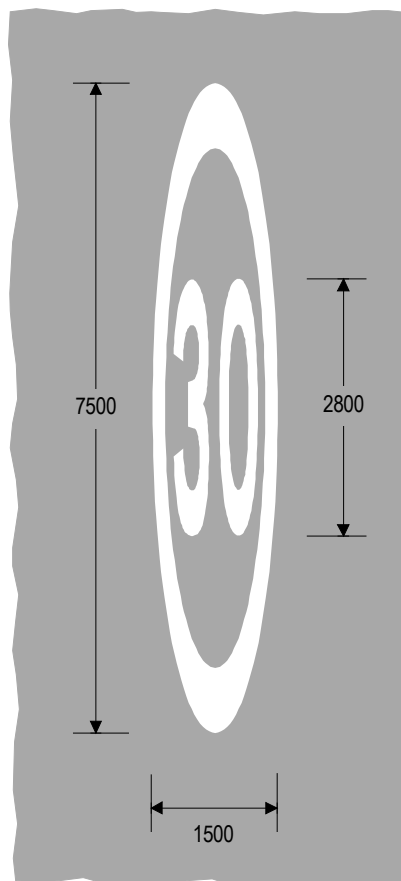
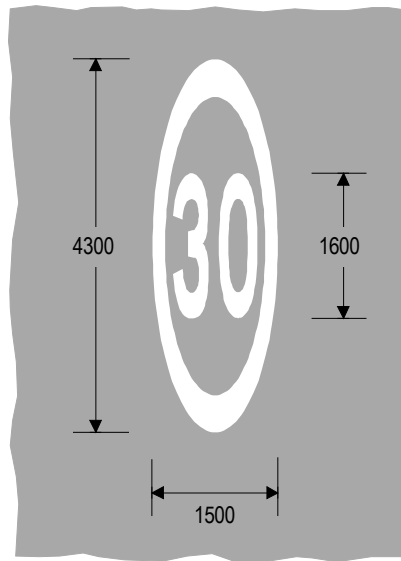

Maximum speed limit  
(Alternative sizes)

Permitted variants: "30" may be varied to "20", "40"  
or "50" or additionally "60" when  
used on a dual carriageway