

**Detail A**  
 1.9m x 3.1m SPEED CUSHION, 75mm high, constructed in asphalt with contrasting coated chippings.

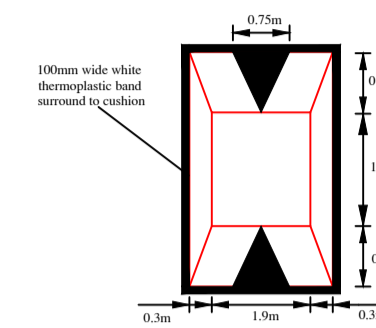

1: 100 (A1)  
 All Dimensions shown in Metres.

**DETAIL 'B'**  
 2 no. 1.9m x 3.1m SPEED CUSHIONS, as per Detail A.

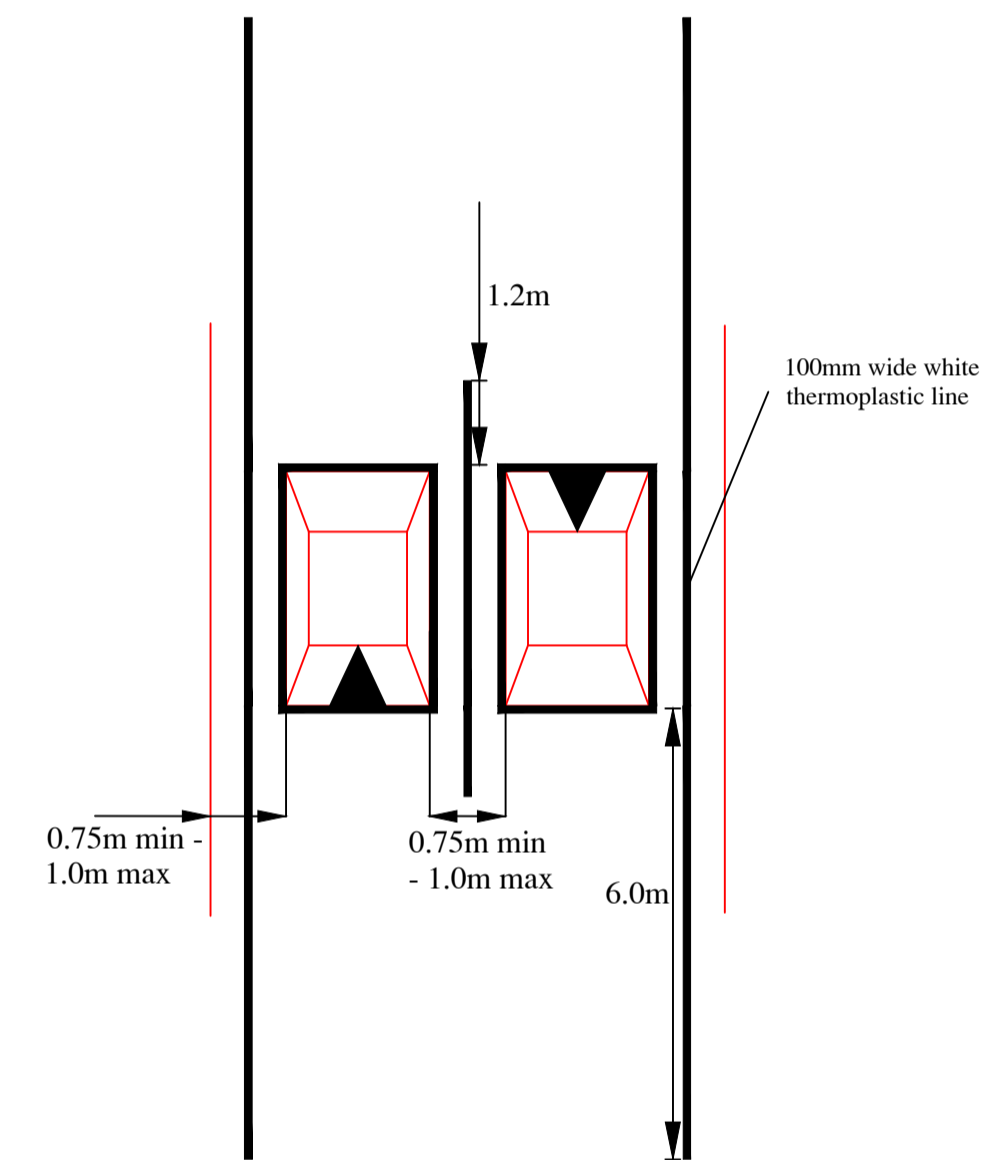

1: 100 (A1)  
 All Dimensions shown in Metres.

**DETAIL 'C'**  
 3 no. 1.9m x 3.1m SPEED CUSHIONS, as per Detail A.

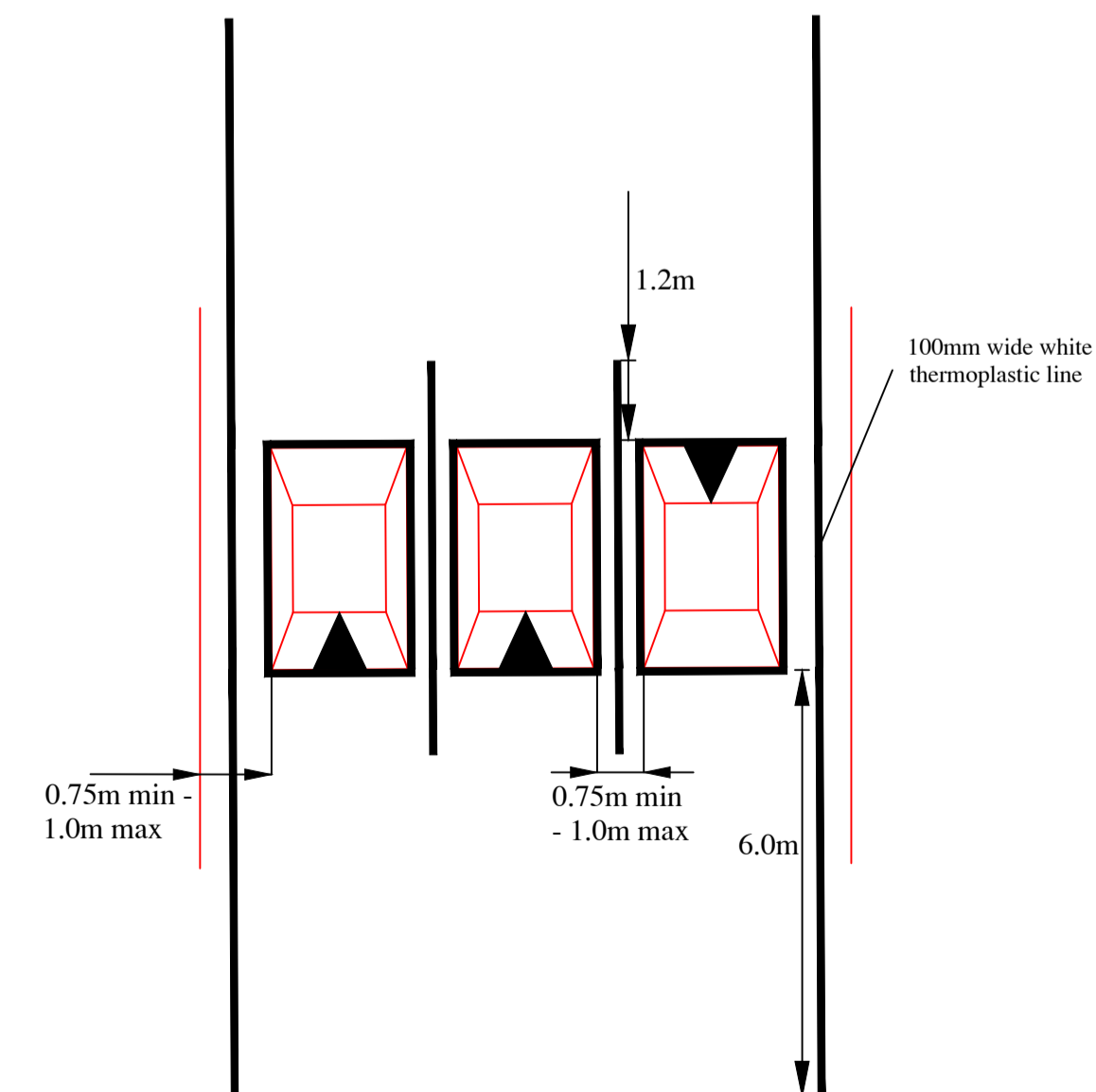

1: 100 (A1)  
 All Dimensions shown in Metres.

**GENERAL NOTES**

- Cushion to follow the existing profile of the carriageway.
- Cushion to be constructed to a height of 75/ 80mm (or as directed).
- Cut chase 500mm x 45mm to the edge of the cushion to receive the surface course asphalt.
- Additional road markings to be agreed by the overseeing organisation.
- 100mm thermoplastic line to extend 6000mm beyond end of ramp along kerbline.
- Detail is for guidance only and is not site specific.
- Surface course to BS594, PART 1:2003 Section 5, Table 6, Column 6/5, with 35% 0/14mm aggregate surface course with 14/20mm coated chippings (PSV 60). Regulating = As surface course on tack coat (Appendix 7/4).

**British Telecommunications plc**  
**IMPORTANT WARNING**  
 Information concerning the location of British Telecommunication plc. telecommunication apparatus is given for your assistance and it is intended for general guidance only; no guarantee is given of its accuracy. It should not be relied upon in the event of excavations or other works made near to British Telecommunications plc apparatus which may exist at various depths and may deviate from the marked route.  
 For free on-site apparatus location and marking service dial 0800 023 2023 and ask for:  
**Freefone " Dial Before You Dig"**

**UTILITY INFORMATION IS FOR GUIDANCE ONLY**  
 THE CONTRACTOR TO CONFIRM EXACT POSITION ON SITE BEFORE ANY WORK COMMENCES.  
 Refer to Roads Service Protocols and Safety Guidance Notes at [www.roadsni.gov.uk/index/contractadverts/contractadverts-noticeboard.htm](http://www.roadsni.gov.uk/index/contractadverts/contractadverts-noticeboard.htm)

AMENDMENT	INITIALS	SIGNATURE	ISSUE	DATE
DRAWN	BG			16/12/19
DESIGNED	BG			16/12/19
CHECKED	**			
APPROVED	**			

PROJECT  
**Derry Traffic Calming**

TITLE  
**Lone Moor Road Traffic Calming Stage 2**

SCALE	DRAWING No.	REVISION
AS SHOWN	?	

**Dfi Roads**  
 Design and Consultancy Services

Derry Section Office  
 1 Crescent Road  
 Derry  
 BT47 2NQ