

Taxi

Inspection Manual

April 2026



Department for

Infrastructure

An Roinn

Bonneagair

Department für

Infrastructure

Index

<u>An Introduction to the Taxi Inspection Manual</u>	Page 3
<u>Approval (M1Type Approval)</u>	Page 6
<u>Construction: General</u>	Page 8
<u>Exterior Interior and Body</u>	Page 12
<u>Fire Extinguishers</u>	Page.15
<u>Insurance (Valid Taxi)</u>	Page 17
<u>Liquid Petroleum gas (LPG)</u>	Page 20
<u>Repair Outfit</u>	Page 21
<u>Roof Signs</u>	Page 25
<u>Seating and Passenger Capacity</u>	Page 29
<u>Steps (general requirements)</u>	Page 35
<u>Taxi Inspection (Recommended Routine)</u>	Page 40
<u>Taximeter Inspection (During Annual Taxi Vehicle Licence Test)</u>	Page 43
<u>Taximeter test</u>	Page 46
<u>Wheelchair Accessibility – Class B Taxis Previously Licensed under the PSV Regulations (1985 & 1995)</u>	Page 51
<u>Wheelchair Accessibility – Class B Taxis Licensed on or after 31 May 2016 under the Taxi Act</u>	Page 60
<u>Annex 1 - Taxi Assessment Guide (Class A & D)</u>	Page 73
<u>Annex 2 - Taxi Assessment Guide (Class B only)</u>	Page 82

An Introduction to the Taxi Manual

Application

The following testing standards are designed to be applied in conjunction with both the Light Vehicle or Heavy Vehicle Manual and the relevant Taxi Assessment Record (H4 or TL3-6).

Taxis first licensed before October 2014 (Test Hall system marked to confirm) are not subject to DVA's Taxi Assessment Guides, but must comply with the related 'Archived' Taxi Assessment Record (H4), and The Taxi Licensing Regulations (Northern Ireland) 2015.

Taxis first licensed from October 2014 must comply with DVA's Taxi Assessment Guides (see Annex 1 & 2) and the related Taxi Assessment Record (H4 or TL3-6), issued on or after October 2014 (each Class B Taxi will have its own individual Taxi Assessment Record TL4).

This manual applies to all vehicles to be licensed as a taxi.

The primary purpose of the manual is to support DVA staff in conducting the annual inspections of vehicles.

The manual is not a legal interpretation of Regulations (therefore it is to be taken as guidance only), and it does not cover all the requirements for all vehicles inspected. In addition to the Vehicle Inspection Manuals, Vehicle Examiners may also consult appropriate legislation before authorising the issuing or refusal of a Taxi Licence.

The legislation that may be consulted includes:-

- Taxi Licensing Regulations (Northern Ireland) 2015
- The Taxis (Taximeters, Devices and Maximum Fares) Regulations (Northern Ireland) 2015
- Taxi Accessibility Regulations (Northern Ireland) 2015
- Motor Vehicle Testing Regulations (Northern Ireland) 2003
- Motor Vehicles (Construction and Use) Regulations (Northern Ireland) 1999

- Road Vehicles Lighting Regulations (Northern Ireland) 2000
- The Road Vehicles (Display of Registration Marks) Regulations 2001

The above legislation is available from 'The Stationary Office', 16 Arthur Street, Belfast, BT1 4GD.

The vehicle must be clean enough to allow the component parts to be inspected and, must not present a health & safety hazard to inspect.

Background

There are 4 classes of taxi; these classes are determined by the type of work they are licensed for.

1. 'Class A' – can pick-up passengers on the streets (subject to Belfast Zone restrictions) and can sit at taxi ranks outside the Belfast Zone.
2. 'Class B' – can pick up passengers on the streets and can sit at any taxi rank, including those in the Belfast Zone, these vehicles must also be wheelchair friendly.
3. 'Class C' – can only be pre booked under a contract, details of the contract must also be carried in the vehicle while the customers are being carried.
4. 'Class D' – are Taxibuses which will be inspected as a taxi but are licensed by DRD to operate a bus type service.

"Belfast Zone" is an area of approximately a two-mile radius from Belfast City centre

Identifying taxi Classes

Examiners may readily identify each individual taxi Class by the following distinguishing features:

- **Class A** – Four doors, right hand drive and fitted with a roof sign and taximeter
- **Class B** – Four doors, right hand drive and fitted with a roof sign, taximeter and wheelchair features, including a wheelchair pictogram on the wheelchair entrance door
- **Class C** – A minimum of two doors. No roof sign, no taximeter and no taxi advertising should be present. May be right or left hand drive, convertible, or an altered heavy vehicle (a standard four door saloon car is also acceptable)
- **Class D** – Four doors, generally a London style cab fitted with a passenger partition; these vehicles are not required to be fitted with a roof sign or taximeter.

Examiners must confirm the taxi Class with the vehicle presenter before conducting the test.

[Back to Index](#)

Approval (M1 Type Approval)

Information

Taxis are required to be constructed in compliance with European M1 Type Approval requirements. From the 31 May 2016, converted vans and altered cars will not be licensed for the first time unless they have been subject to an Individual Vehicle Approval (IVA) test and been formally IVA certified (prior to registration) in compliance with M1 approval requirements. However, in the case of a Class B (wheelchair accessible) taxi, a Driver & Vehicle Agency (DVA) Compliance Confirmation Notice for a Wheelchair Accessible Vehicle (issued following the successful completion of a Voluntary Individual Vehicle Approval (VIVA) test) or a Driver and Vehicle Standards Agency (DVSA formally VOSA) IVA compliance letter, is also acceptable.

M1 confirmation is a function completed by the Passenger Transport Licensing Division (PTLD), therefore a vehicle that has been identified as non-compliant will not be cleared for inspection.

This M1 approval requirement does not apply to taxis which:

- Have been previously licensed before 31 May 2016, or
- Are intended for use as Class C provided they are
 - (i) a motor car unaltered since the original manufacture, or
 - (ii) a Heavy Motor Car (unladen weight exceeding 2540 kgs) or a Motor Vehicle with a Maximum Authorised Mass (MAM) exceeding 3500kgs.

Heavy Motor Cars and Motor Vehicles with a MAM exceeding 3500kgs can be altered.

Method of inspection

Check vehicles which have not been previously licensed before 31 May 2016 for alterations that may compromise M1 certification (accepted modifications to accessories and equipment may include the fitment of steps, alloy wheels, mirrors, steering wheel etc. provided the vehicle and passenger safety is not obviously compromised). Other modifications that may also be accepted include the voluntary fitment of certain wheelchair and wheelchair passenger restraint systems, in taxis other than Class B, provided M1 certification and passenger safety is not obviously compromised.

Vehicles altered and licensed before 31 May 2016 may be accepted on the basis of being previously licensed, provided the alteration does not obviously compromise vehicle or passenger safety.

In the case of a Class C taxi which is not a Heavy Motor Car, or a Motor Vehicle with a MAM exceeding 3500kgs, check that it has not been altered since originally manufactured. The test hall system or the customer's V5c should provide evidence of the original status of a vehicle (e.g. year of manufacture, vehicle make and model).

Reason for rejection

1. A vehicle which has been significantly altered to the extent that it no longer complies with its M1 certification.
2. A Class C taxi which is not a Heavy Motor Car, or a Motor Vehicle with a MAM exceeding 3500kgs, which has obviously been altered since originally manufactured.

[**Back to Index**](#)

Construction: General

Information

The assessment of the general construction and specification of a vehicle to determine its suitability as a taxi will be carried out at the time of the vehicle's initial assessment (with the exception of Class B taxis, similar vehicle models, being unmodified mass produced vehicles, may not be subject to an individual initial assessment, where an assessment record for that particular vehicle make/model exists). Therefore during the annual inspection, the bulk of the 'general construction' inspection will comprise of checking that the vehicle hasn't been altered from the standards recorded on a related 'H4 or TL3-6' at the initial assessment.

Note: while some alterations will generate a refusal, whilst others may be acceptable provided a new initial assessment is completed.

If an examiner considers that a vehicle no longer complies with the standards recorded on the H4 or TL3-6, **they should consult their DCM for further advice and reassessment, if necessary** (all initial assessments must be carried out by the DCM or an appropriately trained examiner).

Method of inspection

Use the relevant H4 or TL3-6 to cross check that the taxi complies with its general construction and specification details.

Check Class A, B, C and D to ensure they have:

- 4 wheels
- A steering wheel

Classes A, B, and D must also have:

- A permanent roof
 - Be not less than 3.96 meters in length
- At least 4 doors (2 on each side) which must be capable of being opened independently from each other
- Passenger doors which can be opened from both the inside and outside by a single operation of the latch mechanism
- Right hand drive steering
- At least 80 litres of luggage space

Note: There is no maximum length for a Class B (wheelchair accessible) taxi.

Class C taxis:

- Must have a minimum of two doors, one of which must be on the nearside and the other door must be on either the offside or the rear
- Are not required to have a permanent roof
- Can be left hand drive
- Are not required to have a luggage space

The 80 litre luggage requirement for Class A, B, and D can also be met either by using a roof rack/top box or a fold down boot lid, provided the number plate can still be read, and where applicable the roof sign is not obscured by any object.

Where a vehicle has 3 rows of seats, the luggage space may be achieved by folding/displacing the rearmost row (these seats will still be counted as part of the maximum seating capacity). It is important that the luggage, when carried in this way, cannot cause an obvious danger to any passenger.

Additional Requirements for Class C vehicles which are Heavy Motor Cars or Vehicles over 3500kg MAM:

- Each passenger must be provided with unobstructed access to 2 doors - 1 door must be located on the nearside, and 1 door must be located on either the offside or rear of the vehicle; it is acceptable for 1 of these doors to be obstructed by a seat that tilts to provide access to the door, and a boarding

ramp or lift that can be readily repositioned to clear the doorway for emergency use.

- Each manually operated door shall be fitted with a slam lock of the two stage type
- Power operated doors shall be fitted in compliance with Schedule 6 of the Construction & Use regulations
- All side doors that open outwards, must be hinged at the front
- Outside door handles must not be more than 1500mm from the ground
- All doors must provide natural light into the vehicle and allow a person to see immediately outside the door (normally fitted with a window).
- A vehicle that does not have a permanent roof must have side rails which are at least 910mm above the floor and at least 455mm above each seat cushion. There must also be rails fitted at the front and rear which shall be at least 1.21m above any part of the floor.

Reasons for rejection

1. A taxi that has been significantly altered and no longer falls within the details of the relevant H4 or TL3-6 (initial assessment), and cannot comply with the criteria of a follow-up initial assessment.
2. A Class A,B,C or D taxi does not have:
 - a) 4 wheels,
 - b) A steering wheel
3. A Class A, B, or D taxi does not have:
 - a) A permanent roof
 - b) A minimum overall length of 3.96 meters.
 - c) At least 4 doors (2 on each side)
 - d) Doors that open independently of each other, and can be opened from both inside and outside the vehicle with one movement of the latch mechanism
 - e) Right hand drive
 - f) At least 80 litres of luggage space

4. A Class C taxi does not have at least:
 - a) 1 door on the nearside, and
 - b) 1 door on either the offside or the rear

5. A Class C taxi which is a Heavy Motor Car or a Motor Vehicle with MAM over 3500kg, which:
 - a) Does not have unobstructed passenger access to 2 doors (1 door located on the nearside, and 1 door located either on the offside or rear of the vehicle). Note: It is acceptable for 1 of these doors to be obstructed by a tilting seat, and/or a boarding ramp or lift, provided these can be repositioned to provide access to the door.
 - b) Has a manually operated door which is fitted with a slam lock not of the two stage type.
 - c) Is fitted with power operated doors which do not comply with Schedule 6 of the C & U regulations
 - d) Is fitted with a side door which opens outwards and is not hinged at the front
 - e) Is fitted with outside door handles which are more than 1500mm above the ground
 - f) Is fitted with doors which do not provide natural light into the vehicle which would not allow a person to see immediately outside the door (normally in the form of a window).
 - g) Does not have a permanent roof and, the side rails are less than 910mm above the floor and, or less than 455mm above the highest part of the seat cushion.
 - h) Does not have a permanent roof and, the front and rear panels or rails are less than 1.21 meters above the floor.

[Back to Index](#)

Exterior, Interior and Body

Information

This inspection applies to all vehicles being licensed for use as a taxi.

The term “primary user” referred to in this section is the first user for which the vehicle was manufactured (e.g. the primary user for a military vehicle would be the Ministry of Defence)

Seats in a 2nd row which tilt or fold to provide access to seats in the 3rd row must be marked with operating instructions, or display a pictogram, to inform passengers how to operate the tilting mechanism when entering or exiting the seat. There is no specific requirement for how these instructions are displayed, however they should be readily understood.

The wheelchair symbol referred to in this section should be of a similar format to the example shown below (required to be displayed on Class B taxis and measuring 150mm by 150mm):



The interior and seating arrangements of a vehicle being assessed for licensing as a taxi must align with a similar vehicle model and H4 or TL3-6. Where the vehicle does not match the standards recorded on a related H4 or TL3-6, **or were the examiner suspects that the interior has been altered in any way, they should consult the DCM for further advice.**

Method of Inspection

Check that the interior, exterior and bodywork of the vehicle are reasonably serviceable and clean, and that the interior matches the specification of a relevant H4 or TL3-6. In particular, look for additions or alterations to the passenger compartment which could:

- Present an obvious risk of injury to passengers, or
- Negatively affect passenger comfort, or
- Compromise the vehicles M1 certification (where applicable).

Where the 2nd row of seats must be folded or tilted to access seats in the 3rd row, check for the presence and condition of signage which informs passengers how to operate the mechanism when entering and exiting the seat.

Check that all Class B taxis display a 'wheelchair sign' (facing outwards) on the door most likely to be used by the wheelchair user boarding the vehicle.

The sign must be:

- Coloured white on a blue background (see above)
- Measure at least 150mm by 150mm

Additional requirements for Class C taxis which are a heavy motor car or a motor vehicle with a MAM exceeding 3500kg:

- Where the vehicle is a decommissioned emergency response or military vehicle, it must be presented with exterior paintwork in a **different colour** (not shade) than that used by the primary user. The same vehicles cannot display markings or exterior equipment that was used by the primary user.
- An adequate means of communication between passengers and driver must be available, were the driver's compartment is separate from the passenger's compartment.

- The vehicle must be capable of providing adequate ventilation without relying on opening any main window or windscreen. The vehicle must be fitted with a means to protect the driver from the effects of glare and reflections caused by artificial internal lighting.

Reasons for Rejection

1. The interior, exterior or bodywork is not reasonably serviceable and clean.
2. The interior differs from the content of a relevant H4 or TL3-6, and cannot comply with a subsequent re-assessment.
3. Seat tilting instruction/signage which is missing, unclear, or which does not readily indicate how the tilting mechanism operates.
4. A Class B taxi which does not display the “wheelchair sign”
5. A Class B taxi, which displays a “wheelchair sign” that :
 - a. Is not fitted on the door most likely to be used by a wheelchair user
 - b. Is not coloured white on a blue background
 - c. Is obviously less than 150mm x 150mm
6. A vehicle which is a class C taxi and is a heavy motor car or a motor vehicle with a MAM of over 3500kg, which:
 - a. Is a decommissioned emergency response or military vehicle, and its exterior paintwork is the **same colour** as that used by the primary user.
 - b. Displays markings or exterior equipment that was used by the primary user.
 - c. Is not capable of providing adequate ventilation without opening a main window or windscreen.
 - d. Does not have adequate means of communication between the passengers and the driver.
 - e. Is not fitted with a means to protect the driver from the effects of glare and reflections caused by artificial internal lighting.

[Back to Index](#)

Fire Extinguishers

Information

This inspection applies to all vehicles licensed as Taxis.

For a fire extinguisher to be “readily available”, it does not need to be within reach of the driver when seated, and it may be carried safely secured in the boot of the vehicle.

Two fire extinguishers, each having a 1 litre capacity, are not accepted as equivalent to one fire extinguisher having a 2 litre capacity.

A missing safety pin is not a reason for rejection, provided the fire extinguisher is still serviceable.

Where a gauge is fitted to a fire extinguisher the reading shown should not be used to determine the condition of the extinguisher.

Method of Inspection

Check that the fire extinguisher is securely mounted and readily available for use.

Ask the presenter to remove the fire extinguisher and check that:

- The fire extinguisher is clearly marked with either BS EN3 or equivalent
- The fire extinguisher contains water or foam
- It has a minimum test rating value of 8A or 34B
- It has a minimum capacity of 2 litres
- There are no other obvious defects which would prevent the fire extinguisher from being serviceable
- The fire extinguisher is securely located where it is unlikely to cause a danger to a person carried in the vehicle (may be located in the boot)

Enter the details of the fire extinguisher onto the PSV values screen.

Reason for Rejection

A fire extinguisher which:

1. Is missing, insecure, or not mounted so that is readily available for use
2. Which has obvious defects that renderer it not serviceable
3. Is not marked with the EN3 standard, or its equivalent
4. Is not marked with at least the minimum test rating of 8A or 34B
5. Is not marked with a minimum capacity of 2 litres
6. Contains anything other than water or foam
7. Is located in such a position that it is likely to cause a danger to a person carried in the vehicle.

[**Back to Index**](#)

Insurance (Valid Taxi)

Information

Valid taxi insurance must be presented at the time of the annual inspection. This inspection applies to all vehicles being licensed as a taxi.

Acceptable form of Vehicle Insurance:

1. A Certificate of insurance (this can be an original certificate or a printed hard copy).
2. A Certificate of insurance presented Electronically:
 - e-mailed direct from the insurance broker to the test centre, or
 - e-mailed direct from the insurance broker to the applicant, and subsequently presented on an electronic device (e.g. Mobile Phone, Tablet or Computer) showing the e-mail with the attached certificate.
Examiners must not handle or touch the electronic device whilst viewing the certificate.
3. A faxed copy of the Certificate, dispatched directly from the insurance broker to the Agency
4. The insurance must remain valid to at least 11.59 pm (approximately midnight) on the day that the Taxi Licensing inspection is successively completed and the Taxi Vehicle Inspection Notice is issued.
5. "Use for hire and reward" need not be specifically stated, but it must not be excluded in the exclusion section of the policy. If, however, it is not stated then the certificate must state 'use for the policyholder's business as a taxi operator' or similar wording which would indicate that the policy is for hire and reward use. In the absence of any indication of hire and reward use, a letter, email or fax direct from either the Insurance Company or the broker, which provides the necessary information, will be required.

6. The insurance certificate must also be able to be linked to the vehicle being presented, ideally giving the registration number, but if this is not the case then a letter, email or fax as above will again be necessary to confirm which vehicle or vehicles in the case of a fleet policy are currently covered.

Large fleet owners who have various schemes agreed with DVA should have this agreement readily available to examiners to access the necessary information. These range from a copy of the policy held at centres with a list of vehicles on a schedule that are covered by that policy, to taxi Insurance policies that cover “any vehicle owned or used by a company”. In this latter case a copy of the certificate must be available to Examiners and an official letter from the Operator must be presented with each vehicle that links it by registration number with that policy.

Method of inspection

During the annual inspection check that the certificate of insurance:

- Is current, and valid to at least 11.59 pm (midnight) on the day of the inspection
- Provides adequate cover for the class of taxi presented for inspection.
- Contains sufficient information to link it directly to the vehicle presented for inspection, or is accompanied with additional documentation which provides a link.
- Is a genuine document/email.

Enter the insurance expiry date into the PSV values screen

Reasons for rejection

1. A taxi insurance certificate that:
 - a) Is not presented at the time of inspection.
 - b) Is not current.
 - c) Does not provide adequate cover for the class of taxi presented for inspection.

- d) Does not contain sufficient information to link it directly to the vehicle presented for inspection, or does not have additional documentation which provides a link.
- e) Is obviously not a genuine document/email.

[Back to Index](#)

Liquid Petroleum Gas (LPG)

Information

Taxis retrofitted and adapted to run on LPG must be presented with a conversion certificate. Alternatively, verification of an approved conversion may be confirmed by using the UKLPG Vehicle Register on the DriveLPG website (accessible via the test hall PCs).

After the conversion has been verified, complete the 'confirmation field' within the G1/PSV values on the test hall system, this will negate asking the presenter for further confirmation.

Method of inspection

During the inspection check, as far as is reasonably practicable, that the conversion certificate:

- Is compliant
- Contains sufficient information to link it directly to the vehicle presented for inspection.
- Is a genuine document.

If a certificate is not produced at the inspection use the vehicle registration number to check that the vehicle is included on the UKLPG register.

Once satisfied that the LPG certification requirements are met, tick the relevant box on the PSV values screen.

Reason for rejection

1. The certificate is not presented at inspection, and confirmation has not been achieved using the DriveLPG website
2. The certificate presented is obviously not genuine
3. The certificate cannot be linked directly to the vehicle, either visually or via the DriveLPG website.

[Back to Index](#)

Repair Outfit

Information

This inspection applies to all vehicles licensed as Taxis, except those which are a Heavy Motor Car, or which have a MAM exceeding 3500kgs.

There are 3 acceptable types of repair outfit: (LV209)

- A spare wheel, jack and wheel brace
- A post puncture repair kit
- Tyres marked as “Run Flat” tyres

Note: A “temporary” or “space saver” type spare wheel is acceptable.

Temporary spare wheel

A temporary spare tyre must have a speed category at least equal to 120 km/h (speed category symbol L). When fitted to the vehicle for temporary use the outward facing surface of the wheel must exhibit a distinctive colour or colour pattern which is clearly different from the colour(s) of the normal units. If it is possible to attach a wheel cover to the temporary-use spare unit the distinctive colour or colour pattern must not be obscured by this wheel cover. A maximum speed warning symbol must be permanently displayed on the outer face of the wheel in a prominent position

Vehicles which have either a post puncture repair kit or run flat tyres are not required to carry a spare wheel, jack or wheel brace.

A post puncture repair kit usually consists of an aerosol of repair fluid and a small compressor, which is powered by an on-board power supply.

Some vehicle models are supplied with the spare wheel area adopted to carry a post-puncture repair kit only, e.g. with a polystyrene insert. Under these circumstances a post-puncture repair kit is acceptable.

A spare wheel may be stored in space specifically designed for its storage, or in the luggage compartment, provided it can be safely secured and provided there is still sufficient storage space for luggage.

Run flat tyres are those which are capable of being operated for a short period when deflated. They should be clearly marked as “Run Flat” or similar.

Method of Inspection

Check that the vehicle has a repair outfit, or is fitted with 4 “Run Flat” tyres.

Where a spare wheel is carried, check that:

- A jack is present for raising the vehicle sufficiently to change each wheel
- A wheel brace or device suitable for loosening and tightening the wheel fixings is present
- The spare wheel is inflated (visual check)
- The spare wheel is not visibly damaged, distorted, or deteriorated such that its use is likely to cause a danger to any road user.
- The tyre has at least the minimum tread depth for the vehicle type
- The wheel or tyre complies with the requirements of the Light Vehicle Manual section “Tyres DVT924”
- The wheel complies with the requirements of the Light Vehicle Manual section “Road wheels DVT925”
- The repair outfit is located so that it is not likely to cause a danger to any person in the vehicle.

Where a post puncture repair kit is carried check:

- Where possible, that the repair fluid is serviceable
- That the kit is complete and suitable for the purpose for which it was designed
- That the kit is located so that it is not likely to cause a danger to any person in the vehicle
- As far as practicable, that the repair kit was supplied as original equipment with the vehicle.

Note: Where the repair fluid has an expiry date which has elapsed, or where any original repair kit components have been replaced with aftermarket products, this is not a reason for rejection.

Where the vehicle is fitted with run flat tyres, check that:

- All tyres are capable of being operated when they are not fully inflated, and are clearly marked as such

Reason for Rejection

1. The vehicle does not have either:
 - a. A spare wheel, jack and wheel brace or similar tool, or
 - b. A post puncture repair kit, or
 - c. Run flat tyres fitted to all wheels

2. Where the vehicle carries a spare wheel:
 - a. A jack missing or obviously not suitable for raising the vehicle
 - b. A wheel brace or similar tool missing, or not suitable for the purpose of loosening and tightening the wheel fixings
 - c. A spare wheel which is obviously not sufficiently inflated
 - d. A spare wheel visibly damaged, distorted, or deteriorated such that its use is likely to cause a danger to any road user.
 - e. A spare tyre worn beyond the legal limit of tread depth.
 - f. A spare tyre which does not comply with the requirements of the Light Vehicle Inspection manual section "Tyres DVT924".
 - g. Any component of the repair outfit is positioned such that there is a risk of injury to passengers or any other road user.

3. Where the vehicle is fitted with a post puncture repair kit which:
 - a. Is obviously incomplete or not serviceable
 - b. Is located so that it is likely to cause a danger to a person in the vehicle
 - c. Was obviously not supplied as original equipment. (see note below)

Note: Where a manufacturers kit is not provided a suitable aftermarket kit may be acceptable.

4. The vehicle has no repair outfit and is not fitted with 4 tyres which are clearly marked as “Run Flat” or similar.

[Back to Index](#)

Roof signs

Information

Only one roof sign is required on a Class A and B taxis; however, it is acceptable for a second roof sign to be voluntarily fitted (the roof sign must not be obscured by any object when **in use**, however, this is not a reason for rejection).

The roof sign must be capable of accommodating the taxi licence plates on the nearside (front and rear), and the information on the roof sign must not be covered by the plates.

Class C Taxis **must not display a roof sign**.

Method of inspection

With the roof sign fitted to the taxi, check that it:

- Is a minimum of 125mm in height
- Is capable of securely accommodating a taxi plate 119mm high and 176mm wide, which can be affixed to the nearside front and nearside rear of the sign. The plate must not (when attached) project higher or longer than the sign and is must be capable of being easily removed without damaging the roof sign or any other vehicle component
- Is fitted so as not to cause a danger to a person in the taxi or a person entering or exiting from it
- Is mounted centrally and positioned transversely, when viewed from the front.
- Does not overhang the roof or measure less than 750mm across. It may however occupy the breadth of the roof
- Does not project more than 250mm above the highest part of the roof
- On Class A taxis, displays to the front on a yellow background in clear and legible black letters the operator licence holder's name or trading name or the word "Taxi".

- On Class B taxis, displays to the front on a white background in clear and legible black letters the operator licence holder's name or trading name or the word "Taxi".
- On Class A and B taxis, displays to the rear on a yellow background and in clear and legible black letters a telephone number or the word "Taxi"
- Illuminates internally to show a steady light to the front and the rear
- Is fused at source against electrical short circuit
- Is not likely to dazzle or cause discomfort to other road users

On a Class B taxi ensure the roof sign includes a wheelchair symbol which must be:

- Placed at the offside front and offside rear of the roof sign where it does not project higher or longer than the roof sign
- Capable of being illuminated from behind
- 125mm wide and 125mm high and is
 - Coloured black and printed directly onto the roof sign, or



- coloured black and printed onto transparent material that is fitted onto the roof sign, or



Is a wheelchair symbol that is transparent on a black background and when fitted onto the illuminated roof sign shows a white wheelchair symbol to the front and a yellow wheelchair symbol to the rear,



London Style Taxis fitted with an integrated cab cap displaying the words 'for hire' or 'taxi' is not regarded as a roof sign.

Reasons for rejection

1. A roof sign:

- a) Which is less than 125mm high
- b) Which cannot securely accommodate a taxi plate (119mm high and 176mm wide) on the nearside front and nearside rear of the sign.
- c) Displaying a plate that projects higher or longer than the sign, or obviously cannot be easily removed without damaging the roof sign or any other vehicle component
- d) That could cause danger to a person in the taxi or a person entering or exiting from it
- e) Which is not mounted centrally and positioned transversely, when viewed from the front
- f) Which overhangs the vehicle roof or measures less than 750mm across the roof (a sign may occupy the breadth of the roof)
- g) Which is projected more than 250mm above the highest part of the roof
- h) Where the taxi is Class A, does not display to the front on a yellow background in clear and legible black letters the operator licence holder's name or trading name or the word "Taxi"
- i) Where the taxi is Class B, does not display to the front on a white background in clear and legible black letters the operator licence holder's name or trading name or the word "Taxi"
- j) Which does not display to the rear on a yellow background and in clear and legible black letters a telephone number or the word "Taxi"

- k) Which does not illuminate internally to show a steady light to the front and the rear
 - l) Which is obviously not fused at source against electrical short circuit
 - m) Which is capable of causing dazzle or discomfort to other road users
2. A roof sign fitted to a Class B taxi which does not include a wheelchair symbol, or has a wheel chair symbol which:
- a) is not 125mm wide and 125mm high
 - b) is not one of the following:
 - a. coloured black and printed onto the roof sign, or
 - b. coloured black and printed onto transparent material that is fitted onto the roof sign, or
 - c. a wheelchair symbol that is transparent on a black background and when fitted onto the illuminated roof sign shows a white wheelchair symbol to the front and a yellow wheelchair symbol to the rear,
 - c) is not positioned at the offside front and offside rear of the roof sign
 - d) projects higher or longer than the roof sign
 - e) is not capable of being illuminated from behind
3. A roof sign fitted to a Class C taxi.

[Back to Index](#)

Seating and Passenger Capacity

Information

The maximum number of passengers a taxi may carry is determined in accordance with The Taxi Licensing Regulations (Northern Ireland) 2015 and DVA's Seating Assessment Policy, at time of the vehicle model's (or for Class B taxis the individual vehicle's) initial assessment. This determination is made on the basis of passenger safety and comfort; vehicle examiners must consider the width, design and comfort of the seat cushions and back rests, floor and foot well spacing, head room, and protrusions within the passenger compartment.

For Class C taxis which are not heavy motor cars or are not a motor vehicle with a MAM exceeding 3500kgs, provided the vehicle has not been obviously altered, determine the seating capacity on the basis that each individual passenger seat is acceptable.

With the exception of Class C taxis, all taxis constructed with 3 rows of forward facing seats (MPV/People Carrier type vehicles) must have unrestricted access to the seats in the 3rd row, and unrestricted access from those seats to the exits on both sides of the vehicle. The vehicle must have a passageway through the 2nd row, or have tilting seats (single or double only) in the 2nd row that allow passengers to exit from both sides of the vehicle. A tilting seat in the 2nd row must be capable of being tilted without disconnecting a seatbelt,

Note:

- With the exception of Class C taxis, all taxis first licensed from 15 January 2018 must have unrestricted access to and from the 3rd row seats (taxis licensed before this date, with restricted access, may continue to be licensed).
- All Taxis fitted with a 3rd row of seats must be marked with operating instructions, or display a pictogram, to inform passengers how to operate the tilting mechanism when entering or exiting the seat. There is no specific requirement for how these instructions are displayed, however they should be readily understood

Seating will be assessed at a particular vehicle models initial assessment, and the information including the class of licence is also recorded on the H4 or TL3-6. When other vehicles of the same make and model are presented to be licensed as a taxi, refer to the information on the H4 or TL3-6 and ensure that it matches.

The taxi will then be licensed on the basis of the H4 or TL3-6 if all the information aligns; passenger capacity will be granted accordingly.

Therefore during the licence inspection the bulk of the seating inspection will comprise of checking that the taxi and its seats have not been altered from the standards recorded at the initial assessment.

Note; while some alterations will generate a refusal, others may be acceptable provided a new initial assessment is completed.

If the vehicle appears to no longer comply with the related H4 or TL3-6, **the examiner should consult the DCM for further advice.**

The maximum number of passenger seats in any taxi is 8. Where a dedicated wheelchair space is provided in a Class B taxi only (space not fitted with a fold down passenger seat and suitable for a wheelchair passenger only) then this space is counted as part of the passenger capacity.

Method of inspection

Use the relevant H4 or TL3-6 to cross check that the taxi complies with the seating capacity and layout details, and record the number of passenger seats on the PSV values screen.

In particular check for:

- Obvious changes to the seating arrangements (this may invalidate the M1 approval, in which case the alterations would be unacceptable)
- Additions to the passenger compartment
- Alternative method of achieving the maximum step height
- Changes which reduce luggage capacity

- Any items specifically mentioned in the H4 or TL3-6, such as requirements for hand holds etc.

All passenger seats that comply with the specified seating requirements must be recorded on the taxi Inspection Notice for licensing purposes. This includes seats that are presented in their folded position (increasing the vehicles load carrying capacity), provided those seats can be readily repositioned to accommodate the carriage of a seated passenger. All passenger seats that comply with the taxi licensing requirements must be recorded on the Taxi Inspection Notice, and the determined seating capacity of the vehicle should not be reduced at the request of the presenter.

In the case of a Class C taxi which is not a heavy motor car or a motor vehicle with a MAM exceeding 3500kgs,

- Provided the vehicle has not been obviously altered, determine the seating capacity on the basis that each individual passenger seat is acceptable.

With the acceptance of Class C taxis, check that all taxis with 3 rows of seats (MPV/People Carrier) and first licensed on or after 15 January 2018 have:

- Unrestricted access to and from the 3rd row of seats
- A passageway through the 2nd row or have tilting seats (single or double only) in the 2nd row, that allow passengers in the 3rd row to exit from both sides of the vehicle (a tilting seat in the 2nd row must be capable of being tilted without disconnecting a seatbelt).
- For seats that must be tilted in the 2nd row to allow access/egress to the 3rd row, clear instructions (or pictograms) on the method of tilting those seats, appropriately located to assist passengers entering and exiting the 3rd row.

Additional Requirements for Class C taxis which are a heavy motor car or a motor vehicle with a MAM exceeding 3500kgs:

- Passengers must have unobstructed access to seats when using the nearside door.

- Each passenger seat cushion must be a minimum of 400mm wide.
- The seating assessment policy contained in the stretched limousine circular (DVOLV219) provides comprehensive guidance.
- All seats must be secured to the vehicle and must not be fitted to a door
- Where a stairway is present, no seat shall be placed close to the stairway where a seated passenger is likely to be thrown down the stairway; a guard or screen of between 800-1100mm in height must be so fitted to prevent such an occurrence
- Passengers must have unobstructed access to two doors, however one door may be obstructed by:
 - A seat which when tilted or folded does not obstruct access to the door, and
 - A lifting platform or ramp which does not obstruct the handle or other device on the inside for opening the door with which the platform or ramp is associated. And, when the door is open, can be pushed or pulled out of the way from the inside so as to leave the doorway clear for use in an emergency.

Reasons for rejection

1. A taxi where the seating arrangements have been altered in such a way that it no longer complies with the detail of the relevant H4 or TL3-6 (initial assessment) and cannot comply with the criteria of a follow-up initial assessment (e.g. a Class A, B, C (motor car only) and D taxi where the seats have been relocated, or obviously replaced with inferior seats or non-original spec. Seats, post registration).
2. A Class C taxi which is not a heavy motor car or a motor vehicle with a MAM exceeding 3500kgs, with seating that has obviously been altered from its original manufacturer specification.

3. A Class A, B or D taxi with 3 rows of forward facing seats (MPV/People Carrier) first licensed from 15 January 2018, with:
- A passageway to/from the 3rd row that restricts the passengers access to either or both side exits, or
 - An outer seat (single or double seat only) in the 2nd row not capable of tilting to provide passenger access/egress to the 3rd row;
 - An outer seat in the 2nd row that tilts to provide access/egress to the 3rd row, fitted with a seatbelt that must be detached to allow it to tilt (only applies to seatbelts with 2 securing buckles)

 - Access/egress to the 3rd row provided by tilting a triple seat.
 - For seats that tilt in the 2nd row to allow access to the 3rd row, instructions (or pictograms) on the method of tilting those seats that are – missing, unclear or located where they do not assist passengers entering or exiting the 3rd row
4. A Class C taxi which is a heavy motor car, or a motor vehicle with a MAM over 3500kgs, where:
- a. A seat is secured to a door, or is not secured in the vehicle.
 - b. A seat is placed so that a passenger is likely to be thrown down a stairway, or a suitable guard or screen 800mm-1100mm in height is not fitted
 - c. More than one mandatory door is obstructed.
 - d. A mandatory door, not being the nearside door, is obstructed by anything other than:
 - i. A seat which when tilted or folded does not obstruct access to the door, or
 - ii. A lifting platform or ramp which:
 - Does not obstruct the handle or other device on the inside for opening the door with which the platform or ramp is associated; or

- When the door is open, can be pushed or pulled out of the way from the inside so as to leave the doorway clear for use in an emergency
- e. A vehicle has more than 8 passenger seats.

[Back to Index](#)

Steps (general requirements)

Information

This section applies to all taxis except taxis licensed before October 2014; these will continue to be licensed in compliance with the basic step requirements that were in place before the publication of the Taxi Assessment Guides (the test hall PSV1 screen has an identifier that informs the examiner that these taxis do not need to comply with the latest requirements).

In this section “pre 2001 Class C light vehicle” means a vehicle which is not a heavy motor car or a motor vehicle with a maximum allowable mass (MAM) exceeding 3500kg, and which was registered before the 1st January 2001.

There are additional requirements for those Class B taxis that have not been previously licensed and are first licensed after 31 May 2016 (see section titled “Accessibility – Class B Taxis Licensed after 31st May 2016 under the Taxis Act”).

With regard to a heavy motor car or a motor vehicle with a MAM exceeding 3500kg (regardless of age) check all general and additional step requirements, as applicable.

All taxi steps (prescribed or otherwise) must be fit for purpose, and be suitable for exiting the vehicle. Steps will be assessed at the vehicle’s initial assessment (or the assessment of a similar vehicle model). Therefore during the annual testing of the vehicle, the inspection of the step will consist of checking that the taxi, or its step, has not been altered from the standards recorded on H4 or TL3-6 at the initial assessment.

Note: while some alterations will generate a refusal, others may be acceptable provided a new initial assessment record (TL3-6) is completed. Where a vehicle does not meet the step requirements it may not necessarily fail, but it may be subject to a further (TL3-6) assessment, with a possible reduction in seating capacity.

Where the vehicle does not match the related H4 or TL3-6, the examiner should **consult the DCM for further advice.**

Where the vehicle has a lowered “foot well”, the step height is measured at the highest point the foot would cross when entering the vehicle.

- A type approved step which was fitted at the time of the vehicle’s manufacture, and protrudes beyond the width of a folded wing mirror, is to be accepted
- Retractable steps must be fitted with a warning device (visual or audible).
- Electrically operated steps must be capable of being operated from the driver’s seat only.
- Vehicles constructed to the maximum width requirements must not be fitted with a fixed step that extends beyond the width of the vehicle

Where an examiner believes that a step has been altered since its initial assessment, **they should contact the DCM for further advice.**

Method of inspection

Whether or not a step has been fitted, check that the step height does not exceed 435mm at any passenger entrance/exit. This does not apply to pre 2001 Class C light vehicles.

Use the relevant H4 or TL3-6 to cross check that the taxi complies with its step/step height detail. Items such as necessary handholds will be recorded on the H4 or TL3-6.

With regard to a passenger step fitted to Class A, B, D, and C taxis (excluding pre 2001 Class C Light Vehicles) check that:

- The front edge of each tread surface has a band of colour measuring between 45mm and 50mm in width which contrasts with the remainder of the tread.
- The step does not protrude beyond the width of the vehicle or beyond the width of a folded mirror (unless fitted at the time of manufacture)
- Handholds, where specified in the H4 or TL3-6, are in a serviceable condition
- It is not obviously less than 95mm deep, including the accepted inset
- It is not obviously less than 95mm deep (disregarding any inset, where passengers do not exit directly from a seat beside the door).

With regard to any step fitted to a Class A, B, D, and C taxis (excluding pre 2001 Class C light vehicles) check that:

- It is properly constructed and fit for purpose
- It is covered in a slip resistant material
- It is secure
- It has not been damaged to the extent that its function is compromised
- It is not likely to injure any person

Where a retractable or folding step is fitted to any taxi, check:

- That the deployment mechanism works as originally intended.
- A warning device is fitted to alert the driver that the step is deployed
- That electrically operated steps can only be activated from the driver's seat.

Note: A device which prevents the vehicle being driven whilst the step is extended can be accepted as an alternative to the required warning device.

A pre 2001 Class C light vehicle is not required to meet the step height; however where any step is voluntarily fitted, check that:

- It is fit for purpose and properly maintained

- It is covered with a slip resistant material
- If it is retractable a warning device is fitted to alert the driver that the step is deployed

The following paragraph describes additional requirements relating to a Class C taxi which is a heavy motor car or a motor vehicle with a MAM exceeding 3500kgs:

When examining steps fitted to a Class C taxi which is a heavy motor car or a motor vehicle with a MAM exceeding 3500kgs, check also that;

- Where a passenger exit has more than one step (flight of steps), the vertical distance between each riser is not less than 120mm and not more than 250mm, and
- Where a passenger exit has more than one step (flight of steps), hand rails must also be provided to assist passengers entering and exiting the vehicle.

Reasons for rejection

1. A Class A, B, D or C taxi (excluding pre 2001 Class C light vehicles) with a passenger exit/entrance step which:
 - a. Exceeds 435mm in height
 - b. Protrudes beyond the width of the vehicle or beyond the width of a folded mirror (unless approved and fitted at the time of the vehicle's manufacture).
 - c. Does not have a band of colour measuring between 45mm and 50mm in width along the front edge of the tread surface which contrasts with the remainder of the tread.
 - d. Does not have the required handholds specified in the related H4 or TL3-6, or where they are not in a serviceable condition.
 - e. Is obviously less than 95mm deep including the accepted 20mm inset, or where the accepted 20mm inset is not readily usable.
 - f. Is obviously less than 95mm deep (disregarding any inset, where passengers do not exit directly from a seat beside the door).

2. A Class A, B, D or C taxi (excluding pre 2001 Class C light vehicles) with any step which:
 - a. Is obviously not properly constructed and fit for purpose
 - b. Is not covered in a slip resistant material.
 - c. Is insecure
 - d. Is obviously damaged to the extent that its function is compromised
 - e. Is likely to injure a person

3. A retractable or folding step:
 - a. With a defective deployment mechanism
 - b. With a missing or defective warning device
 - c. Which is electrically operated step and which cannot be activated from the driver's seat.

4. A step fitted to a pre-2001 Class C light taxi which is:
 - a. Not fit for purpose or properly maintained
 - b. Not covered in a slip resistant material
 - c. Retractable and which does not have a warning device to alert the driver that the step is deployed
 - d. Likely to injure any person

5. A Class C taxi which is a heavy motor car or a motor vehicle with a MAM exceeding 3500kgs, and the passenger exit has more than one step (flight of steps):
 - a. The vertical distance between a riser is less than 120mm or more than 250mm
 - b. Not fitted with hand rails to assist passengers entering and exiting the vehicle.

[Back to Index](#)

Taxi Inspection (Recommended Routine)

This inspection routine has been written with the intent of integrating taxi testing into the existing light vehicle inspection process. A heavy vehicle taxi inspection, due to the increased level of flexibility in the heavy process, may not follow the routine as detailed here; however, this document may be used as guidance for the checks required in such an inspection.

Vehicle Arrives at Stage 1

- Check the Registration and log onto the vehicle.
- Bring the vehicle to stage one, conduct the normal stage one checks and also:
 - Check the insurance and enter the expiry date onto the test hall system PSV Values
 - Check the LPG Certification, if applicable, and tick the box on the test hall system PSV Values
 - Return paperwork to the presenter
 - Enter the correct taxi class onto the test hall system PSV Values
- Send the data forward and continue to stage 2.
- At the stage 2 terminal, check for a H4 or TL3-6 for the vehicle. If there is no H4 or TL3-6 which suits the vehicle, **consult the DCM; an Initial Inspection may be required.**
- Where the vehicle has been assessed as a Class B taxi with a dedicated wheelchair space (space suitable for a wheelchair passenger only) the G1/PV1 screen should be completed to separately record the number of dedicated wheelchair passengers (e.g. 2 wheelchair passengers, and 6 seated passengers). The total number of passengers must not exceed 8.
- Where a wheelchair space may also be used by a seated passenger (space fitted with a fold down seat e.g. London Cab) then the maximum number of seated passengers only should be recorded

- If the vehicle is LPG, and no certificate was presented, check the vehicle registration on the Drivelpg website, and tick the box as appropriate.
- Check the fire extinguisher, and enter the details on the test hall system.
- Continue the normal stage 2 checks, remembering to:
 - Check the roof sign for illumination and compliance
 - Check that the condition of the interior and exterior is serviceable
 - Check for alterations within the passenger compartment
 - Check the step height if required
 - Check the step condition and Colour Contrasting strip, if required.
 - Check the step for suitability/alterations
 - Check the operation of the rear internal door handles
 - Check for wheelchair symbols if required
 - Check for seat tilting instructions if required
- Ask the presenter to exit the vehicle and get them to:
 - Remove the fuel cap
 - Open the boot
 - Display the repair outfit
 - Operate retractable steps and show the warning device function.
 - Display any wheelchair and occupant restraints so that you can inspect their condition
 - Deploy the wheelchair ramp, if applicable.
- Carry on with stage 2, 3 and 4 as normal, however at stage 3 if there is a meter fitted check for security, seals etc. and at stage 4, ensure that the tyres on drive axle are the same size listed on the taximeter plaque.
- When completing the test, ensure that all the required details on the test hall G1/PV1 screen are completed. This is vitally important as this information will be used to complete the taxi licence request, and ultimately manufacture the taxi plates.
- Give the vehicle Inspection Notice to the presenter; or

- Give the Notification of Refusal to the presenter and where appropriate, advise the presenter of the need for the taximeter to be tested and sealed before the vehicle is presented for retest.

Notes:

- If an initial assessment is required (new TL3-6), be sure that the DCM (or appropriately trained examiner) informs you of the approved seating capacity, and the seating capacity is recorded on the test hall system BEFORE you complete the test.
- If an initial assessment is required, you may be asked to assist your DCM (or appropriately trained examiner) with the process when you have finished the normal stage 2 checks. This will help both you and them streamline the inspection process.

[Back to Index](#)

Taximeter Inspection (During Annual Taxi Vehicle Licence Test)

Booking staff will have confirmed that a taximeter test has been successfully completed before appointing a Class A or B vehicle for test.

During the Taxi Vehicle Licence Test, checks are limited to ensuring that the taximeter switches on, the seals are intact, the taximeter plaque is present and readily legible, the tyre sizes on the vehicle drive axle match those recorded on the plaque and the registration number on the taximeter plaque matches the registration number on the vehicle. This inspection applies to all taxis fitted with a taximeter.

Method of inspection

Check the test hall system to confirm that the vehicle's taximeter details have been recorded on the G1/PV1 screen and a calibration plaque is secured on the nearside door post

- Confirm that the taximeter details are recorded on test hall system and a taximeter and printer is fitted in the vehicle
- Ensure that the taximeter and printer is secured in the vehicle
- Ask the vehicle presenter to switch the taximeter on and view the display
- Check that the taximeter is sealed to the vehicle and the taximeter programme ports are also sealed; confirm that all seals are intact
- Ensure the taximeter plaque is secured to the vehicle and the recorded details are readily legible (no obvious tampering)
- Confirm the 'drive axle' tyre size matches the related details recorded on the taximeter plaque
- Confirm the registration number on the taximeter plaque matches the vehicle.

Reasons for Rejection

- a. A required taximeter or printer is not fitted in the vehicle
- b. The taximeter or printer is not secure in the vehicle
- c. The taximeter does not switch on
- d. The taximeter display screen is obviously inoperative or the display screen details cannot be readily read
- e. The taximeter is not sealed to the vehicle, or the taximeter programme ports are not sealed
- f. The taximeter plaque is missing, is not readily legible, or has obviously been tampered with
- g. A drive axle tyre size is different to that recorded on the taximeter plaque
- h. The registration number on the plaque does not match that of the vehicle
- i. A taximeter fitted to a Class C or D taxi

Note: Examiners must issue a (Taxi Vehicle Licence) Notice of Refusal where a required taximeter or printer is not fitted, or where a taximeter defect is identified (e.g. seals broken, display screen defective, tyre size different to that recorded on the plaque). The taximeter must be tested and sealed before the Taxi Vehicle Licence retest is conducted; customers will be charged a taximeter test fee, plus a taxi vehicle retest fee.

However, the customer will be charged a vehicle retest fee only, where the taximeter plaque is missing, provided the taximeter seals are intact and no taximeter defects have been identified and the tyre sizes are the same as those recorded on the G1/PV1 screen. In this case, examiners are advised to view the Taximeter Test details on the G1/PV1 screen and complete a 'duplicate' taximeter plaque (Test Centre, Check-sum, Vehicle Registration, Tyre Size, Pulses per Mile, and date of the taximeter test). Finally, the examiner must fix the plaque to the vehicle (usually on the 'B' post of the

nearside door). Where a taximeter plaque is to be replaced in this manner a customer receipt should also be printed to ensure the vehicle registration number matches that of the vehicle. Where this is not the case (e.g. cherished transfer) a full taximeter test will be required, and a taximeter test fee will be payable.

[Back to Index](#)

Taximeter Test

Information

The taximeter test is a standalone inspection, requiring a separate log on to the test hall system. This inspection applies to all vehicles which intend to be licensed as a Class A or Class B taxi.

Vehicles which are to be used as a Class C and Class D taxis must **not** be fitted with a taximeter.

Taximeters are permitted to be programmed with a range of different tariffs that incorporate a number of different fare rates, provided the Maximum Fare is not exceeded on any prescribed date or time of day. Taximeters may be programmed with the Maximum Fare tariff, with a bespoke tariff, or with a bespoke tariff and test tariff (a test tariff is required where it is not possible to carry out the calibration check using the bespoke tariff).

This section of the taxi inspection manual contains the general procedures and reasons for rejection for taximeter tests. Detailed guidance on the verification and sealing of specific meters is contained within the Taximeter Testing, Sealing & Receipt Printer Verification Instructions (TM1), which is updated regularly. The TM1 should be used to guide examiners during the inspection.

Method of inspection

Taxi Meter Test

Inspection Process (prior to on-road)

- Log on to the test hall system and select the vehicle registration number for the taximeter test, having ensured that the correct vehicle is presented for inspection.

- Check that the vehicle appears suitable for licensing as a Class A or Class B taxi e.g. has 4 doors, 4 wheels, and a permanent roof and is right hand drive etc.
- Walk around the vehicle and conduct a cursory inspection to ensure the vehicle is not in a dangerous condition; (i) tyres are not obviously cut or bulged, tyres on the drive axle are the same size, are not worn below the legal limit, wheel studs /nuts are present and appear to be appropriately secured, and body panels appear intact and deemed unlikely to cause a danger.
- When seated in the vehicle check that (i) the examiner's seatbelt functions normally,(ii) the view to the road is not dangerously impaired,(iii) where visible, MIL lamps are not illuminated, indicating a defect that would cause a vehicle to fail a roadworthiness test,(iiii) there is no obvious and dangerous braking or steering defects (may also be assessed on-road).
- Check that a DVA approved taximeter and printer combination is fitted (1 taximeter only may be fitted).
- Ensure the taximeter and printer are appropriately located and secured; the display screen can be readily seen by a passenger with the taximeter capable of being sealed to the vehicle and the taximeter program capable of being sealed in the taximeter.
- Where visible, ensure all signal generator connections and ports are protected against tampering.
- Confirm that the initial fare charge displayed does not exceed the maximum initial regulated charge.
- Check that an approved program is imbedded (see program check-sum recorded on Approved Taximeter List TM2).
- Check the taximeter and printer is capable of being switched on and functions correctly by obtaining a technical report and ensure the date and time on the printout is within +/- 10 minute tolerance.

- **DO NOT PROCEED ONTO THE ROAD IF ANY OF THE ABOVE ARE NOT COMPLIANT** and issue a notice of refusal stating the reason.
- The examiner may continue to the on-road check.

Inspection Process (on-road)

- Direct the driver to align the front wheel of the vehicle at the first road check marker (starting point), and select the taximeter 'Stopped' mode (the taximeter must be tested in this mode as it will only record distance travelled, regardless of the time taken).
- Direct the driver around the test route, and check the taximeter 'fare drop' at the various check markers, to ensure that the taximeter calibration is within tolerance (plus or minus 2 car lengths at the first check marker and plus or minus 4 car lengths at the last check marker).
- At the end of the road test, switch the taximeter from the 'Stopped' mode to the 'Hired' mode (whilst retaining the existing fare); on the next fare drop activate the stop watch and record the time (waiting time) to the next fare drop. Confirm that the waiting time does not exceed the Maximum regulated fare (Approval list TM2 refers)
- Print a receipt and confirm that all required details are present and correct (vehicle registration number, current date, journey start time, journey end time, distance travelled, fare charged (equates to distance & time only), extras, and Total fare (equates to distance, time & extras)).
- **Test the printer/taximeter default**; ask the customer (mandatory) to remove the paper from the printer (the taximeter must not allow "For Hire" to be selected with the printer paper removed).
- When the road test is successfully complete, seal the taximeter to the vehicle and seal the taximeter programme ports (supplementary guidance is contained in the Taximeter testing manual (TM1) re. the testing and sealing individual taximeters, printer makes and models, and conducting tests where bespoke tariffs and dedicated 'test tariffs' are programmed in the taximeter)

- Record the taximeter and vehicle details on the calibration plaque, and the test hall G1/PV1 screen.
- Complete and attach the calibration plaque to the vehicle (usually on the 'B' post of the nearside door).

Reasons for Rejection

- a) The vehicle is obviously not suitable for licensing as a Class A or Class B taxi e.g. does not have 4 doors, or 4 wheels, or a permanent roof, is not right hand drive etc.
- b) The tyres on the drive axle are not the same size
- c) Taximeter or printer models not recorded on the DVA approval list
- d) The taximeter or printer is not adequately secured to the vehicle
- e) The taximeter display screen cannot be readily seen by at least one passenger
- f) The taximeter cannot be readily sealed to the vehicle, or the programme ports cannot be readily sealed
- g) Visible signal generator ports are not protected against tampering
- h) The taximeter does not switch on, or the fare displayed exceeds the initial Maximum fare (see current fares)
- i) No paper in the printer, or the printer does not switch on
- j) The taximeter allows "For Hire" to be selected when the printer paper has been removed
- k) Unable to print a customer receipt / technical report containing: the programme checksum, K-factor/pluses per mile and the current date and time
- l) Unable to print a customer receipt containing: the vehicle registration number, current date, journey start time, journey end time, distance

travelled, fare charged (distance and time) and Total fare (distance, time and extras)

- m) The vehicle registration number on the customer receipt does not match the vehicle.
- n) The checksum number recorded on the technical report is not recorded on the list of approved taximeters
- o) The taximeter date is incorrect, or the time is outside the tolerance (plus or minus 10 minutes) or not increasing in increments
- p) The taximeter is obviously defective or not functioning correctly (unable to select 'Stopped' or 'Hired' mode)
- q) The taximeter is displaying a fare exceeding the Maximum fare applicable to any check marker point; calibration is outside the set tolerance (plus or minus 2 car lengths at the first check marker and plus or minus 4 car lengths at the last check marker)
- r) The waiting time is obviously exceeded

Notice of Refusal

Examiners are advised to issue a notice of refusal where a dangerous defect is identified either prior to, or during the 'on the road' test.

Where the defect has been identified before the 'on the road' test, the examiner may issue the notice of refusal and terminate the test

[Back to Index](#)

Wheelchair Accessibility – Class B Taxis Previously Licensed Under the PSV Regulations (1985 & 1995)

Information

This inspection applies to all Class B taxis that had a PSV licence in force at any time during the year preceding 31 May 2016.

For the purpose of this section, restraint means a belt or other suitable device, which can be attached to a wheelchair or is intended to be worn by its occupant and is designed to prevent or lessen injury in the event of an accident.

The assessment is based on the wheelchairs and their occupants being restrained in either a forward facing position, or in a rearward facing position in an M1 approved vehicle having an integral partition fitted at the time of the vehicle approval that supports the wheelchair and wheelchair occupant.

A vehicle constructed for the carriage of a forward facing wheelchair, fitted with 4 tie down straps locating into 4 anchorage points and a 3 point seatbelt for the wheelchair occupant, independent of each other is acceptable (it is acceptable for a wheelchair restraint and an occupant restraint belt to be secured at the same anchorage point).

Where the vehicle has a forward facing wheelchair position and the wheelchair securing system is either a 'docking system' or 'clamping system', a visual assessment of the system will be required to ensure that the wheelchair can be restrained in the vehicle (a 3 point seatbelt for the wheelchair occupant will also be required).

Note: the minimum dimensions for a three point seatbelt, used by the occupant of a forward facing wheelchair (the minimum height of the upper anchorage is 1100mm, and the minimum distance between both lower anchorage points (where fixed to the floor) is 300mm).

Where the vehicle has a rearward facing wheelchair position and the vehicle is M1 approved with an integral partition (e.g. London style cab), it may be assumed that the vehicle's wheelchair anchorages and restraint systems comply with the approval requirements. This securing system may have only 1 wheelchair anchorage with a double hook restraint located on the wheelchair, and an occupant lap belt (seatbelt). Where the vehicle has been assessed as a Class B taxi with a dedicated wheelchair space (space suitable for a wheelchair passenger only) the G1/PV1 screen should be completed to separately record the number of dedicated wheelchair passengers (e.g. 2 wheelchair passengers, and 6 seated passengers). The total number of passengers must not exceed 8.

Where a wheelchair space may also be used by a seated passenger (space fitted with a fold down seat e.g. London Cab) then the maximum number of seated passengers only should be recorded

The detachment and relocation of a passenger seat/s is **only** accepted for the purpose of providing a wheelchair space. The following conditions must be met:

- Detached seats must be moved to a safe storage location **in the taxi**, where they cannot be used by a seated passenger
- Only **single** type passenger seats (original fitment or bespoke) may be detached and relocated in the taxi e.g. it is not acceptable for a double or triple passenger seat to be detached and relocated.
- Detachable seats (original fitment or bespoke) must be capable of being quickly released, where no tools are required to either detach the seat or secure the seat in its stored location, minimising any unnecessary delay
- Seats that have been moved to provide a wheelchair space **must** be readily secured in the taxi (ratchet straps are recommended), where **no** exits are blocked from use by other seated passengers in that compartment, and where there is no obvious risk to passenger/driver safety.

Alternative, for rear loading wheelchair only, where it is not practical to relocate the seat/s to a position where all side exits in the compartment remain unobstructed, it is acceptable for a detached seat to be located to a position where it is blocking an exit in the compartment, provided the following conditions are met:

- the wheelchair entrance remains unobstructed, and
- the only passenger carried in that compartment is the wheelchair passenger (no passenger seats in that compartment may be used for that journey).
- Seats that have been moved to provide the wheelchair space must be assessed in their licensed seating location and in their stored location during the vehicle's Initial Assessment, to confirm there are no obvious risk to passenger/driver safety.
- Relocated seats must not reduce the mandatory luggage capacity of the taxi

The wheelchair symbol referred to in this section should be of a similar format to the example shown below (required to be displayed on Class B taxis and measuring 150mm by 150mm):



Method of Inspection

Check that the wheelchair restraint system complies with one of the following minimum requirements:

- The vehicle is an M1 approved vehicle, designed to carry a rearward facing wheelchair, with an integral partition based restraint system, or
- The vehicle is designed to carry a forward facing wheelchair and is fitted with a 4 point tie down system (or a docking or clamp based

system which appears to offer an equivalent level of safety) for the wheelchair and a 3 point seatbelt for the wheelchair occupant (it is acceptable for a wheelchair restraint and an occupant restraint to be secured at the same lower anchorage point).

Check that all Class B taxis display a 'wheelchair sign' (facing outwards) on the door most likely to be used by the wheelchair user boarding the vehicle.

The sign must be:

- Coloured white on a blue background (see above)
- Measure at least 150mm by 150mm

With the exception of vehicles that were previously licensed as Belfast Public Hire (which may be assumed as meeting equivalent wheelchair space requirements) check for the presence of a suitable wheelchair space which is:

- At least 1200mm measured longitudinally x 700mm measured transversely (see note below)
- At least 1200mm high, measured vertically from the floor (see note below)
- Predominately flat
- Front or Rear Facing only

Note: An occupied wheelchair will not utilise the entire wheelchair space, therefore certain protrusions into that space may be acceptable. Protrusions into the wheelchair space (theoretical box created by the wheelchair space dimensions of 1200mm/700mm/1200mm) may be accepted provided the protrusions do not obviously prevent the occupied wheelchair from being manoeuvred to its travel location, or obviously prevent the wheelchair or wheelchair occupant from being safely and comfortably secured in that location (see pictograms below). Individual cases may need referred to the DCM or HQ for further guidance.

Examples of minor protrusions into the wheelchair space.

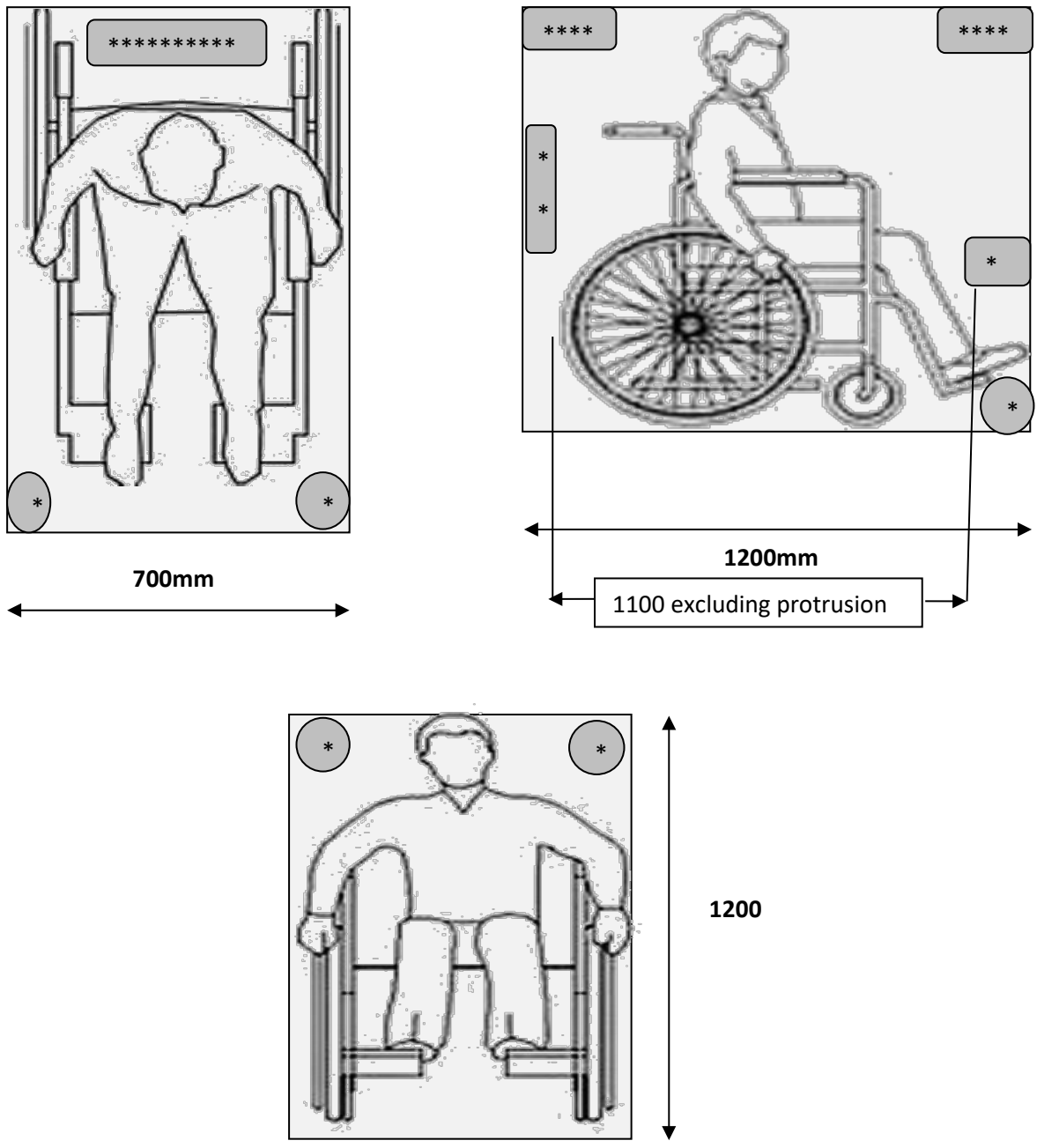

Check that any protrusions into the wheelchair space

- Do not obviously prevent an occupied wheelchair from being manoeuvred to its travel location
- Do not obviously prevent a wheelchair or wheelchair occupant from being safely and comfortably secured in the travel location

Check that an unoccupied wheelchair (either folded or otherwise) can be stored securely and is not likely to injure a person in the vehicle.

Check that the wheelchair anchorage points:

- Are capable of holding a wheelchair securely in place
- Are attached to the chassis or the floor
- Are not likely to injure a person carried in the vehicle
- Where attached to the floor, are mounted using a galvanised plate on the underside of the floor which is at least 3mm thick and 200mm square

Check that the wheelchair restraints and occupant restraints

- Are independent of each other
- Where the vehicle is constructed for the carriage of a forward facing wheelchair, the wheelchair is secured with a 4 point tie down system, and the vehicle is fitted with a 3 point seatbelt for the wheelchair occupant
- Have the minimum dimensions for a three point seatbelt, used by the occupant of a forward facing wheelchair (the minimum height of the upper anchorage is 1100mm, and the minimum distance between both lower anchorage points where fixed to the floor is 300mm).
- Are not likely to injure a person carried in the vehicle

Note: Wheelchair restraints, occupant restraints, and their anchorage points should be assessed using the criteria for comparable items in the Light Vehicle Manual under the section “DVT904 Seat Belts and Supplementary Restraint Systems (SRS)”

Check that boarding ramps or lifts:

- Are suitable for the loading and unloading a wheelchair and its occupant
- Are not likely to slip or tilt when in use
- Can be stowed safely when not in use
- Are not likely to injure a person carried in the vehicle.

Check that any seat that has been detached and relocated for the purpose of providing an occupied wheelchair space

- is a single seat (double or triple seats must not be detached)
- is capable of being quickly released and secured without using tools
- is safely and securely stored in the taxi, where it cannot be used by a seated passenger and where no exits are blocked (see note below)
- does not reduce the mandatory luggage capacity of the taxi

Note: For rear loading wheelchairs only, it is acceptable to detach and relocate a seat where it is blocking a side exit, provided the only passenger carried in the same compartment on that journey, is the wheelchair passenger.

Reasons for Rejection

1. Wheelchair or occupant restraints which:

- a. Are missing or incomplete
- b. Do not secure the wheelchair and the occupant independent of each other.
- c. Are likely to injure a person carried in the vehicle
- d. Are fitted in a vehicle constructed to carry a rearward facing wheelchair and occupant, where the vehicle is not an M1 approved vehicle with an integral partition (i.e. not a London style cab)
- e. Are not a 4 point wheelchair tie down system (or a docking or clamp based system which appears to offer an equivalent level of safety), or a 3 point seatbelt for the wheelchair occupant. This only applies to vehicles constructed to carry a forward facing wheelchair and occupant.
- f. The minimum height of the upper anchorage point is less than 1100mm and the distance between both lower anchorage points is less than 300mm
- g. Do not comply with the equivalent assessment criteria under “DVT904 Seat Belts and Supplementary Restraint Systems(SRS)”

2. A wheelchair space which :
 - a. Is less than 1200mm measured longitudinally x 700mm measured transversely (see note below)
 - b. Is not predominately flat
 - c. Does not face to the front or rear
 - d. Is less than 1200mm in height, measured vertically from the floor (see note below)
 - e. Has a protrusion that obviously prevents the occupied wheelchair from being manoeuvred to its travel location
 - f. Has a protrusion that obviously prevents the wheelchair or wheelchair occupant from being safely and comfortably secured in the travel location
 - g. A vehicle that was previously licensed as a Belfast Public Hire taxi, which has been obviously altered, and can no longer accommodate an occupied wheelchair

3. Where an unoccupied wheelchair can only be accommodated within the passenger compartment (either folded or otherwise), but cannot be safely secured and is likely to injure a person in the vehicle.

4. Wheelchair anchorage points which:
 - a. Are not capable of holding a wheelchair securely in place
 - b. Are not attached to either the chassis or the floor
 - c. Are likely to injure other passengers
 - d. Are mounted on the underside of the floor using a galvanised plate that is obviously less than 3mm thick or 200mm square, or where no suitable plate is fitted.
 - e. Are insecure, weakened, inappropriately altered, or damaged so that their function is impaired

5. A wheelchair ramp or lift which:
 - a. Is missing
 - b. Is unsuitable for loading or unloading the wheelchair and its occupant.

- c. Is likely to slip or tilt when in use.
 - d. Is not capable of being stored safely when not in use
 - e. Is likely to injure to a person carried in the vehicle
6. A detached and relocated seat (to provide an occupied wheelchair space), which:
- a. is a double or triple type seat
 - b. cannot be quickly released and securely relocated in the taxi, without using tools
 - c. can be used by a passenger in its relocated position
 - d. is blocking an exit, where the wheelchair is loaded from the side
 - e. reduces the mandatory luggage capacity
7. A Class B taxi which does not display the “wheelchair sign”
8. A Class B taxi, which displays a “wheelchair sign” that :
- a. Is not fitted on the door (facing outwards) most likely to be used by a wheelchair user
 - b. Is not coloured white on a blue background Is obviously less than 150mm x 150mm

Wheelchair Accessibility – Class B Taxis Licensed on or after 31 May 2016 under the Taxis Act

Information

This inspection applies to all Class B taxis which are first licensed on or after the 31 May 2016.

For the purpose of this section, restraint means a belt or other suitable device, which can be attached to a wheelchair or is intended to be worn by its occupant and is designed to prevent or lessen injury in the event of an accident.

The assessment is based on the vehicle being an M1 type approved wheelchair accessible vehicle (WAV), and will include an inspection to confirm that the seating and wheelchair features, fitted at the time of the vehicle's manufacture/approval and recorded on the related TL4 during the taxi's initial assessment, have not been obviously altered.

The detachment and relocation of a passenger seat/s is **only** accepted for the purpose of providing a wheelchair space. The following conditions must be met:

- Detached seats must be moved to a safe storage location **in the taxi**, where they cannot be used by a seated passenger
- Only **single** type passenger seats (original fitment or bespoke) may be detached and relocated in the taxi e.g. it is not acceptable for a double or triple passenger seat to be detached and relocated.
- Detachable seats (original fitment or bespoke) must be capable of being quickly released, where no tools are required to either detach the seat or secure the seat in its stored location, minimising any unnecessary delay
- Seats that have been moved to provide a wheelchair space **must** be readily secured in the taxi (ratchet straps are recommended), where **no** exits are blocked from use by other seated passengers in that compartment, and where there is no obvious risk to passenger/driver safety.

Alternative, for rear loading wheelchair only, where it is not practical to relocate the seat/s to a position where all side exits in the compartment remain unobstructed, it is acceptable for a detached seat to be located to a position where it is blocking an exit in the compartment, provided the following conditions are met:

- the wheelchair entrance remains unobstructed, and
- the only passenger carried in that compartment is the wheelchair passenger (no passenger seats in that compartment may be used for that journey).
- Seats that have been moved to provide the wheelchair space must be assessed in their licensed seating location and in their stored location during the vehicle's Initial Assessment, to confirm there are no obvious risk to passenger/driver safety.
- Relocated seats must not reduce the mandatory luggage capacity of the taxi

The wheelchair symbol referred to in this section should be the same format and colour as the example shown below (required to be displayed on Class B taxis and measuring 150mm by 150mm):



Method of Inspection

Check that the wheelchair restraint system complies with one of the following minimum requirements, and is either:

- A vehicle constructed for the carriage of a rearward facing wheelchair (e.g. London style cab) and is an M1 approved vehicle with an integral partition based restraint system, or

- A vehicle constructed for the carriage of a forward facing wheelchair and is an M1 approved vehicle with a 4 point tie down system for the wheelchair (or a docking or clamp based system which appears to offer an equivalent level of safety), and a 3 point seatbelt for the wheelchair occupant, (it is acceptable for a wheelchair restraint and an occupant restraint to be secured at the same anchorage point).

Note: the minimum dimensions for a three point seatbelt, used by the occupant of a forward facing wheelchair are as follows – the minimum height of the upper anchorage is 1100mm, and the minimum distance between both lower anchorage points where fixed to the floor is 300mm).

Where the vehicle has been assessed as a Class B taxi with a dedicated wheelchair space (space suitable for a wheelchair passenger only) the G1/PV1 screen should be completed to separately record the number of dedicated wheelchair passengers (e.g. 2 wheelchair passengers, and 6 seated passengers). The total number of passengers must not exceed 8.

Where a wheelchair space may also be used by a seated passenger (space fitted with a fold down seat e.g. London Cab) then the maximum number of seated passengers only should be recorded

Inspect the wheelchair and occupant restraints and anchorage points, and check:

- That the wheelchair and occupant restraint systems are independent of each other
- That the wheelchair and occupant restraint anchorage points are secure, not weakened or inappropriately altered
- That they are not likely to injure a person carried in the vehicle
- The presence and condition of straps and buckles etc.

Note: Wheelchair restraints, occupant restraints, and their anchorage points should be assessed using the criteria for comparable items in the Light Vehicle Manual under the section “DVT904 Seat Belts and Supplementary Restraint Systems (SRS)”

Check for the presence of a suitable wheelchair space which

- Is at least 1200mm measured longitudinally x 700mm measured transversely (see note below)

- Has at least 1350mm head room when measured vertically from the floor of the wheelchair space (see note below)
- Is front or rear facing
- Has internal lighting suitable for illuminating the space
- Has a slip resistant surface.

Note: An occupied wheelchair will not utilise the entire wheelchair space, therefore certain protrusions into that space may be acceptable. Protrusions into the wheelchair space (theoretical box created by the wheelchair space dimensions of 1200mm/700mm/1350mm) may be accepted provided the protrusions do not obviously prevent the occupied wheelchair from being manoeuvred to its travel location, or obviously prevent the wheelchair or wheelchair occupant from being safely and comfortably secured in that location (see pictograms below). Individual cases may need referred to the DCM or HQ for further guidance.

Examples of minor protrusions into the wheelchair space.

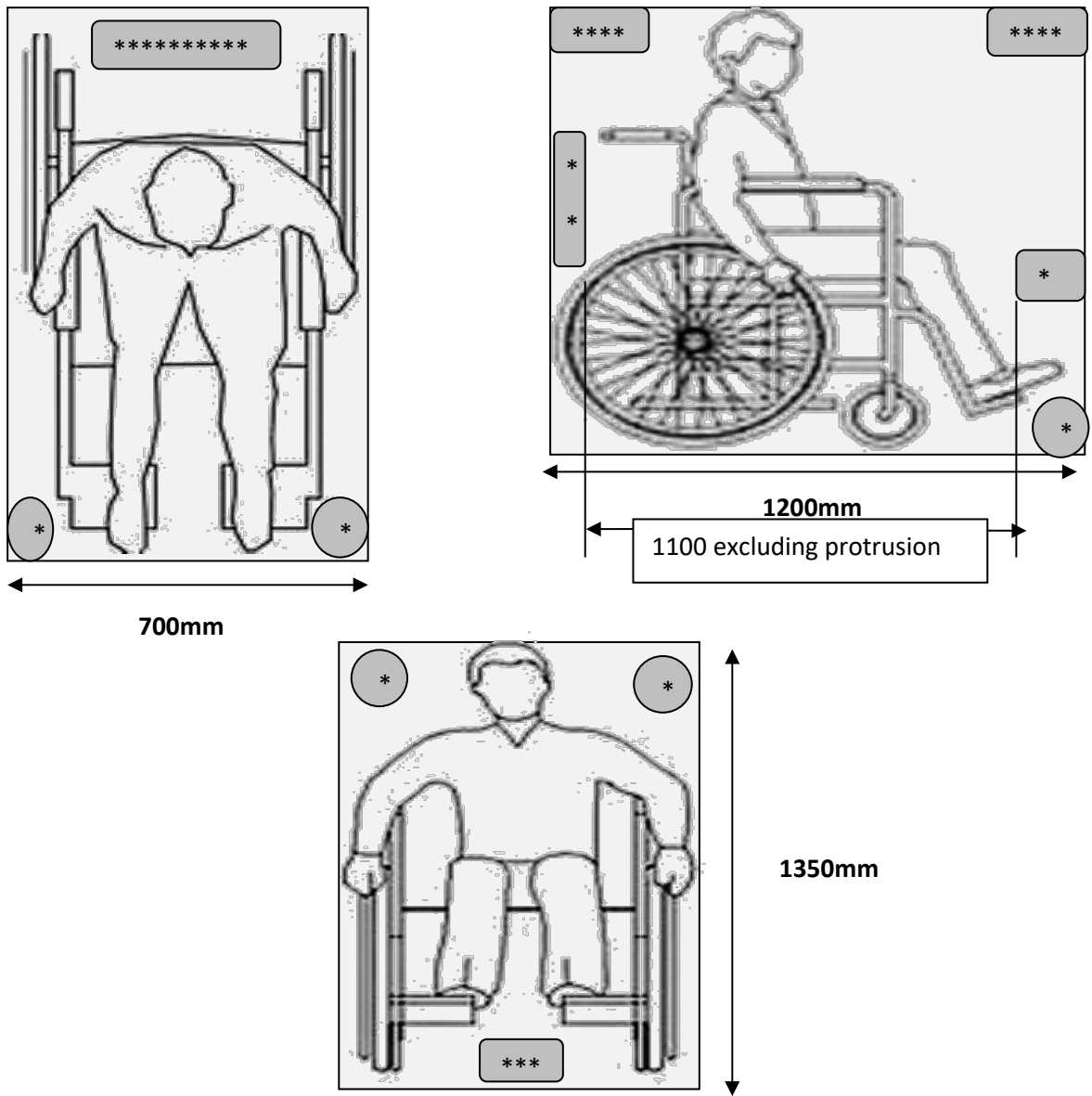

Check that any protrusions into the wheelchair space

- Do not obviously prevent an occupied wheelchair from being manoeuvred to its travel location
- Do not obviously prevent a wheelchair or wheelchair occupant from being safely and comfortably secured in the travel location

Check that the area for storing the wheelchair is:

- At least 735mm x 330mm x 805mm
- Suitable to safely and securely store a folded wheelchair where it is not likely to injure any person carried in the vehicle

Boarding Ramps and Lifts

Check for the presence of at least:

- One boarding lift, or
- One boarding ramp, or
- One Portable ramp (may be made up of two or more pieces but when in use is one continuous ramp)

Ask the presenter to deploy the lift or ramp and check that:

- It can provide wheelchair access to either the nearside or rear of the vehicle
- It is free from sharp edges or protrusions which may cause injury
- It is free from damage which prevents it's safe use

Check that any boarding ramp or portable ramp:

- Is not less than 700mm wide
- Is marked around each of the edges with a band of contrasting colour at least 50mm wide
- Has a single continuous surface when deployed
- Does not have a slope which exceeds 16 degrees, when the ramp is deployed and resting on a block 125mm in height

Where a portable ramp is carried in the vehicle, also check:

- For the presence of adequate storage space, and when stored that the ramp is unlikely to injure any person carried in the vehicle
- When stored the ramp is readily available for use
- The ramp is not likely to slip or tilt when in use

Note: An alternative ramp solution may be acceptable if it provides an equivalent level of safety and functionality.

Entrance/Exits

Check that the entrance/exit for a wheelchair user:

- Is located at either the nearside or the rear of the vehicle
- Is at least 750mm wide.
- Is at least 1235mm in height.
- The occupied wheelchair must have unobstructed access through the aperture and, to the wheelchair space

Wheelchair Sign

Check that all Class B taxis display a 'wheelchair sign', (facing outwards) on the door most likely to be used by the wheelchair user boarding the vehicle.

The sign must be:

- Coloured white on a blue background (see "information")
- Measure at least 150mm by 150mm

Communication Devices (partition between driver and passenger compartment)

Taxis which have a partition between the driver and passenger compartment must be fitted with an intercom and induction loop system (an induction loop is a system which allows direct transmission of the intercom output to a hearing aid. It will not be possible to test the operation of the induction loop).

Taxis with a partition and induction loop system must display a sign as shown below:



In vehicles with a partition between the driver and passenger compartment, check that:

- An intercom system and induction loop system is fitted
- The intercom system is operational (it will not be possible to check the operation of the induction loop system)

- An induction loop sign is displayed in the passenger compartment.

Steps

All passenger steps must not exceed 435mm in height and an Accessibility Step must be fitted at one nearside passenger entrance/exit where any passenger step exceeds 380mm in height.

Check that a required Accessibility step complies with the following:

- Is at least 200mm deep and 400mm wide
- Has a band of contrasting colour of at least 50mm width and located around and abutting each of the edges of the step
- Is covered in a slip resistant material
- Is not obviously sloped

Note: An Accessibility Step is not required where all passenger steps are at a height of 380mm or less.

Where a flight of steps is fitted, check that:

- The difference in height between any 2 steps does not exceed 200mm, measured between the tread of each step or measured from the floor of the vehicle to the tread of the first step.

Check that all other passenger steps comply with the requirements applicable to all Class A and D taxis, Class B taxis that were previously licensed prior to 31 May 2016 and Class C vehicles registered on or after 1 January 2001 [see section titled 'Steps(general requirements)].

Handholds and Handrails

Where an Accessibility Step is fitted to a nearside entrance/exit to comply with the 380mm height requirement, a handhold or handrail must also be provided at that entrance/exit. Check that the handhold/handrail is:

- Present at the entrance/exit fitted with the step
- Has a slip resistant surface
- Capable of being firmly gripped by a passenger
- Contrasting with the parts of the vehicle adjacent to them
- Secure and fit for purpose

Detachable Seats

Check that any seat that has been detached and relocated for the purpose of providing an occupied wheelchair space

- is a single seat (double or triple seats must not be detached)
- is capable of being quickly released and secured without using tools
- is safely and securely stored in the taxi, where it cannot be used by a seated passenger and where no exits are blocked (see note below)
- does not reduce the mandatory luggage capacity of the taxi

Note: For rear loading wheelchairs only, it is acceptable to detach and relocate a seat where it is blocking a side exit, provided the only passenger carried in the same compartment on that journey, is the wheelchair passenger.

Reasons for Rejection

1. Wheelchair or occupant restraints which:
 - a. Are fitted in a vehicle constructed to carry a rearward facing wheelchair and occupant, where the vehicle is not an M1 approved vehicle with an integral partition (i.e. not a London style cab)
 - b. Are not a 4 point wheelchair tie down system (or a docking or clamp based system which appears to offer an equivalent level of safety), or a 3 point seatbelt for the wheelchair occupant. This only applies to vehicles constructed to carry a forward facing wheelchair and occupant.
 - c. The minimum height of the upper anchorage point is less than 1100mm and the distance between both lower anchorage points is less than 300mm (where fixed to the floor)
2. Wheelchair and occupant restraint systems which:
 - a. Do not secure the wheelchair or the occupant
 - b. Are not independent of each other.

- c. Have anchorage points that are insecure, weakened, inappropriately altered, or damaged so that their function is impaired
 - d. Are likely to injure a person carried in the vehicle
 - e. Do not comply with the equivalent assessment criteria under “DVT904 Seat Belts and Supplementary Restraint Systems(SRS)”
3. A wheelchair space which is missing, or:
- a. Is less than 1200mm measured longitudinally x 700mm measured transversely (see note below)
 - b. Has less than 1350mm head room when measured vertically from the floor of the wheelchair space (see note below)
 - c. Is not front or rear facing
 - d. Has no internal lighting suitable for illuminating the space
 - e. Does not have a slip resistant surface.
 - a. Has a protrusion that obviously prevents the occupied wheelchair from being manoeuvred through the door aperture and to its travel location
 - b. Has a protrusion that obviously prevents the wheelchair or wheelchair occupant from being safely and comfortably secured in the travel location
- 4 A wheelchair storage area which:
- a. Is less than 735mm x 330mm x 805mm
 - b. Cannot safely or securely store a folded wheelchair where it is not likely to injure a person carried in the vehicle
- 5 A wheelchair boarding lift, or a boarding ramp, or a portable ramp, used by wheelchair users to enter and exit the vehicle, which:
- a. Is missing
 - b. Does not provide access to the wheelchair entrance/exit, located on

- either the nearside or the rear of the vehicle
 - c. Has sharp edges or protrusions which are capable of causing injury
 - d. Is damaged, preventing its safe use
- 6 A boarding ramp or portable boarding ramp, which:
- a. Is less than 700mm wide
 - b. Is not in a serviceable condition
 - c. Is not marked around the edges with a band of contrasting colour at least 50mm wide
 - d. Does not have a single continuous surface when deployed
 - e. Has a slope which exceeds 16 degrees, when the ramp is deployed and resting on a block 125mm in height
- 7 A portable boarding ramp, which:
- a. Is not securely stored where it is unlikely to injure a person carried in the vehicle
 - b. Is not stored where it is readily available for use
 - c. Is likely to slip or tilt when in use
- 8 A wheelchair user entrance/exit which :
- a. Is not located at either the nearside or the rear of the vehicle
 - b. Is less than 750mm wide
 - c. Is less than 1235mm in height
- 9 A vehicle with a partition between the driver and passenger compartment which:
- a. Is not fitted with an intercom system or induction loop system
 - b. Has an intercom system or induction loop system which is obviously defective (it will not be possible to check the operation of the induction loop system)
 - c. Does not display an induction loop sign.
- 10 The vehicle does not have at least one Accessibility Step fitted at a nearside

entrance where required or the Accessibility Step:

- a. Is more than 380mm in height
- b. Is less than 200mm deep or 400mm wide
- c. Does not have a band of contrasting colour of at least 50mm in width, located around and abutting each of the edges of the step
- d. Is not covered in a slip resistant material
- e. Is obviously sloped (greater than 3 degrees)

Note: An Accessibility Step is not required where all passenger steps are at a height of 380mm or less.

- 11 Where a flight of steps is fitted, the difference between any 2 steps exceeds 200mm.
- 12 All other passenger steps do not comply with the general step requirements [see section titled 'Steps (General Requirements)'].
- 13 A handhold or handrail which is fitted on one nearside entrance (having a step not more than 380mm in height) which:
 - a. Is missing
 - b. Is insecure or not fit for purpose
 - c. Is not capable of being firmly gripped by the passengers
 - d. Does not have a slip resistant surface
 - e. Is not coloured to contrast with other adjacent parts of the taxi
- 14 A detached and relocated seat (to provide an occupied wheelchair space), which:
 - a. is a double or triple type seat
 - b. cannot be quickly released and securely relocated in the taxi, without using tools
 - c. can be used by a passenger in its relocated position
 - d. is blocking an exit, where the wheelchair is loaded from the side
 - e. reduces the mandatory luggage capacity

15 A Class B taxi which does not display the “wheelchair sign”

16 A Class B taxi, which displays a “wheelchair sign” that :

- a. Is not fitted on the door (facing outwards) most likely to be used by a wheelchair user
- b. Is not coloured white on a blue background
- c. Is obviously less than 150mm x 150mm

[Back to Index](#)

Taxi Assessment Guide (Class A and Class D only)

This guide has been produced to assist the Driver & Vehicle Agency (DVA) examiners with their initial assessment of a motor car to determine its suitability as a Class A or Class D taxi. It focuses on the vehicle's general construction as it affects passenger access, egress and seating capacity. The guide should be read in conjunction with The Taxi Licensing Regulations (Northern Ireland) 2015 and the Taxi Inspection Manual.

It will be applied to a vehicle at the time of its initial taxi licensing assessment. This guide may also provide customers with advanced knowledge of the DVA's taxi inspection criteria.

The Detail

Vehicle length

All taxis must be a minimum of 3.96m in length. There is no maximum vehicle length other than what is quoted in the Construction and Use Regulations.

Tyre loads

Where quoted, record the axle weights and tyre load indices on the Inspection Report (TL3 or TL6), having confirmed that the tyres are suitable for the vehicle weights.

Steering wheel

The steering wheel must be on the right hand side of the vehicle when viewed from a forward facing front seat

Steps

The maximum distance from the ground to the top tread of the lowest step of every passenger entrance or exit on a vehicle must not be more than 435mm. For the tread area (area on a vehicle that is immediately below a closed door), to be

regarded as a suitable step/platform, it **must** be capable of supporting and assisting a passenger to safely alight from the vehicle.

Where the original step/platform of the entrance or exit exceeds 435mm from the ground (measured at the highest point on the vehicle where a passenger's foot would have to cross whilst entering/exiting) an additional fixed (including retractable/folding step) step must be provided at each passenger entrance or exit.

A step must not project beyond the body of the vehicle, unless it can be repositioned so as not to extend beyond the body whilst the vehicle is in motion. This requirement does not apply to a vehicle fitted with a step supplied by the vehicle manufacture as original equipment, provided all other step requirements are met. Electrically operated steps must be capable of being controlled from the driver's seat.

NB: A fixed step is acceptable if it extends beyond the body of the vehicle, but is retained within the width of a folded mirror, provided that mirror has been fitted at the time of the vehicle's manufacture.

- Each step must be a minimum of 95mm in width and have the tread area covered in a slip-resistant material.

It is not necessary for the full 95mm step width to project outwards beyond the sill of the vehicle; it is acceptable for not more than 20mm of the step to be 'inset' from the outer edge of the sill, provided the complete step is sufficient to accommodate a person's heel. However, it is important to note that where the step is used to exist from the 3rd row of the vehicle, the full 95mm step width must project outwards beyond the sill.

- Where a vehicle is fitted with a retractable/folding step, the vehicle must have an automatic warning device fitted to it (buzzer or warning lamp) to warn the driver that the step is deployed.
- There must be a band of colour of between 45-50mm across the front edge of each step, and the band of colour must contrast with the remainder of each step
- Each step must be soundly and properly constructed and fitted in such a manner that it is unlikely to injure a passenger or other road user.

Handholds and Handrails

Where a passenger steps into a vehicle other than directly from the ground, a handhold or handrail may be provided, where necessary, to assist passengers to safely access or egress the vehicle. All handholds and handrails must be capable of being easily and firmly gripped. Examiners are advised to pay particular attention to the need for handholds, where the minimum step width only, is provided.

Permanent Top (roof)

All vehicles must be fitted with a permanent top (roof) *i.e.* the roof is not capable of being positioned to completely uncover all seats.

Doors

All vehicles must have at least four doors, two of which must be located on each side of the vehicle. Passenger doors must be capable of being readily opened from the inside and outside of the vehicle by one operation of the latch mechanism, and must be capable of being opened independently from each other.

Luggage

When all passenger seats are occupied, the vehicle must have a luggage capacity of 80 litres; the luggage space should be separate from the passenger's compartment and be broadly equivalent to two small-medium sized 'carry-on' suitcases.

For vehicles that have a 3rd row of passenger seats (MPV/ people carrier) the required luggage space may be achieved by folding the 3rd row of seats, provided there is no obvious risk to the passenger's safety (examiners must continue to include the 3rd row of seats when determining the maximum passenger capacity).

*Examiners are advised to use discretion when assessing the luggage space.
N.B. The luggage capacity for most vehicles may be obtained from manufacturers' sales brochures or through internet searches which may be relied upon for assessment purposes.*

Where the luggage compartment is used to accommodate the spare wheel (e.g. an LPG tank has been located in the spare wheel well), a volume of 35 litres may be assumed for the spare wheel. Therefore, the luggage compartment must be assessed capable of carrying the 35 litre spare wheel, plus 80 litres of luggage.

Other acceptable methods of achieving the luggage capacity:

- A roof-rack
- An open boot lid that is capable of providing a safe and secure luggage carrying platform (the number plate must be easily read when the boot lid is used for this purpose)
- Where a partition is fitted between the driver and rear passenger compartment, the front passenger seat can be tipped-up to provide the required luggage space (any luggage carried must be capable of being safely secured).

Seating

Seating assessment involves a range of elements that must be considered simultaneously:

1. Cushions
2. Contoured seating
3. Width of seats (including folding seats)
4. Retractable/fold-up armrests
5. Access to the rearmost row of seats (including MPV's)
6. Protrusions in the passenger compartments
7. Leg room
8. Headroom

Examiners are advised to position the seats in compliance with the minimum dimensions recorded at the Annex, prior to assessment, and to note that it is acceptable for the back rest of any seat to be positioned not more than 90 degrees from the horizontal plane.

Cushions

All seats must be properly cushioned and upholstered in cloth, leather or artificial leather. All cushioned seats must provide reasonable comfort for passengers

Contoured seating

The space between two contoured seats may be assessed suitable as a seat when it complies with all of the above requirements, including the requirement for reasonable passenger comfort.

Width of seats (including folding seats)

The width of every allocated passenger seat shall be **at least** 400mm, and

A continuous seat accommodating 3 passengers must have a minimum dimension of 1200mm measured across the front edge of the seat cushion. In addition, there must be a minimum dimension of 1300mm measured around 150mm forward of and parallel with the seat back, at a height 600mm above the uncompressed seat cushion (passenger shoulder location); a back rest measuring less than 1300mm may be accepted (see the Annex dimensions for E, F and G).

The depth of any passenger seat cushion (distance between front edge of seat cushion and the seat back rest) must be assessed on an individual basis as related passenger comfort is interdependent on available leg room.

Retractable/fold-up armrests

When assessing the suitability of a seat backing incorporating an integrated arm rest, examiners must ensure that the seat back provides adequate passenger comfort when the arm rest is in the raised position.

Access to and from the 3rd row of seats, where all vehicle seats are forward facing

There are several elements to the assessment of the 3rd row of forward facing seats, all of which must be considered simultaneously and ultimately considered capable of providing passengers with reasonable access/egress without assistance.

Access and egress must be provided to both side doors only, and can be accepted if achieved by:

- Removal of one outer seat or the centre seat, in the 2nd row of seats to provide a suitable and safe access, or
- Tilting of the seats on the 2nd row to provide safe and reasonable access to the 3rd row of seats; *when exiting from the 3rd row, a passenger must be capable of positioning the seats to afford reasonable access to all side doors in the passenger compartment. The instructions for moving the seats must be clearly marked on the back **and** side of the seats as appropriate (a pictogram providing clear instruction is acceptable).*

When considering seat access the examiner must also consider:

- The size and suitability of the passage-way when the 2nd row seats are displaced
- Hand holds that may be required to assist a person when exiting from the 3rd row of seats
- Suitability of steps

Not more than a double seat may be tilted to provide a suitable passage-way/access to the side door. The examiner shall decide if the type of seats are acceptable; there are two different types of seat systems for consideration, however, **where any of the outer seats in the 2nd row of seats have seatbelt systems that require the belts to be disconnected from the seat to allow the seat to tilt, this seat system is considered unacceptable:**

Note: it is not acceptable to have detachable seatbelts fitted to the outer seats in the second row, where their fitment prevents reasonable access/egress to the 3rd row

- Standard seating provided in mass produced vehicles are considered acceptable (provided the seatbelt system complies with the above requirements, and all seating and interior dimension requirements are met) and where the tilted seats expose fixtures in the flooring; these should be ignored for assessment purposes.
- Alternative type approved seating; It is impossible to make a blanket judgement on this type of seating as they can be so varied they can only be assessed on an individual basis. The examiner's decision will be based on a passenger who is not

familiar with the vehicle being able to understand the process of how to tilt the seat (the complexity of the tilting mechanism) and the ease in which it tilts (the weight of the seat).

The passage-way to the door aperture must be of an adequate size to allow a person to access the doorway. At the doorway, a **departure area** must be provided to allow a person to stabilize themselves before exiting safely from the vehicle. If the departure area is not capable of accommodating both of the passenger's feet at the same time, suitable **handholds must be provided** to ensure that a person can stabilize themselves before and during the exiting process.

Where the departure area is in a lowered 'footwell' the datum for the maximum step height measurement of 435mm shall be taken from the highest edge where a foot would have to cross whilst entering or exiting from the vehicle.

The '**departure area**' is a rectangular space to simulate an area where a passenger could stand with both feet side by side prior to departure from the vehicle; it should be predominantly flat and have a minimum dimension of 300mm x 200mm, the smaller side (200mm dimension) shall be between parallel and 45 degrees from the door aperture and the same side shall be not more than 200mm from the outside edge of the vehicle.

Leg room

The following minimum leg room requirements must be available to ensure reasonable passenger comfort:

- There must be a space of at least 275mm measured between the vehicle floor and the top foremost/centre edge of each uncompressed seat cushion (see the Annex dimension C), this requirement does not apply where the presence of a transmission tunnel reduces the leg room.
- There must be a clear space of at least 630mm measured longitudinally from the lowest central position of each passenger back rest (see the Annex dimension A).
- There must be a clear space of at least 200mm measured longitudinally from the foremost edge of each passenger seat cushion (see the Annex dimension D); this requirement does not apply to any area directly above a transmission tunnel. In addition, the 200mm clear space requirement may be reduced to 150mm, where a centre console (located between the front seats) protrudes into the rear passenger compartment.

- There must be a space of at least 400mm measured between the foremost edges of each opposing passenger seat cushion.
- Where a passenger's legs are required to straddle the transmission tunnel, that tunnel must not exceed 300mm in width at its highest point.

Headroom

There must be a minimum height of 880mm measured vertically from the lowest central position of each uncompressed passenger seat cushion to the head cloth (see the Annex dimension B)

The Annex

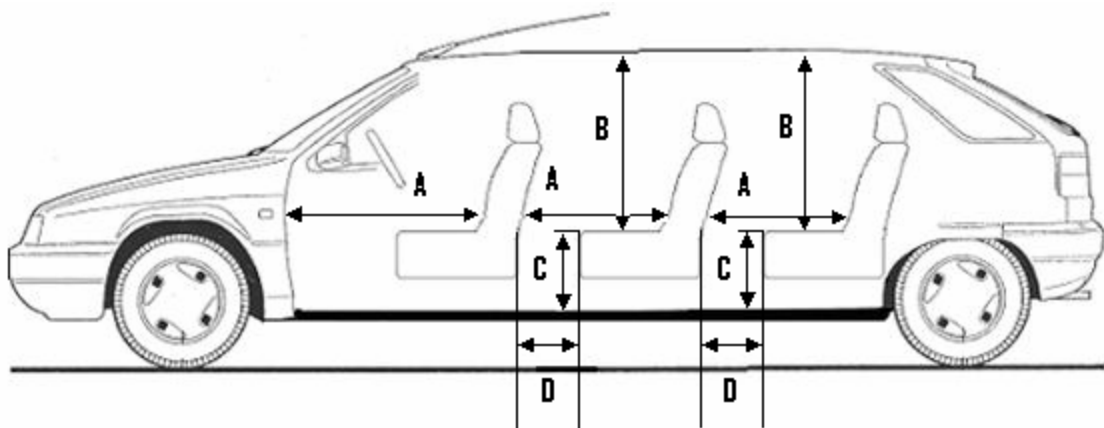

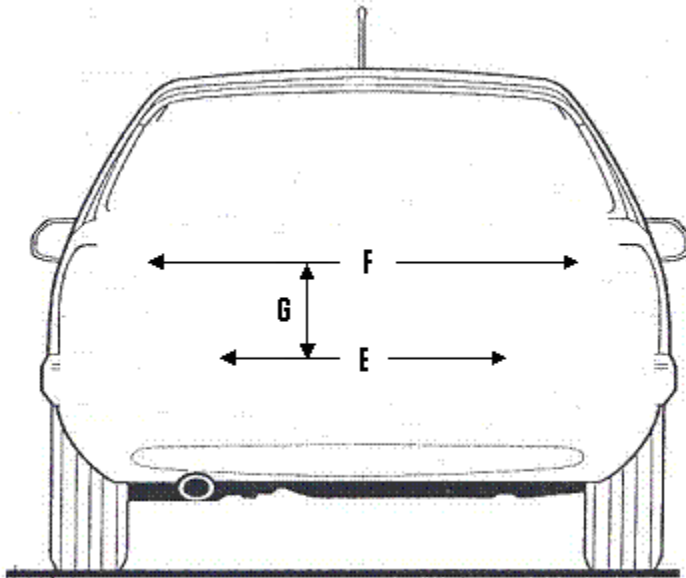

<u>Dimension</u>	<u>Description</u>	<u>mm</u>
A	Front seat minimum dimension between the seat back cushion and the dash	630
A	Minimum distance between seat back and seat cushion rearward of it	630
B	Minimum headroom	880
C	Minimum height of seat squab; Cushion not compressed	275
D	Minimum distance for leg room	200
E	Minimum width for 3 continuous seats	1200
F	Minimum width for 3 passengers at shoulder height	1300
G	Distance between seat cushion and shoulder height dimensions	600

[Back to Index](#)

Taxi Assessment Guide (Class B only)

This guide has been produced to assist the Driver & Vehicle Agency (DVA) examiners with their initial assessment of a motor car to determine its suitability as a **Class B (wheelchair accessible) taxi**. It focuses on the vehicle's general construction and accessibility features as they affect passenger access, egress and seating capacity. The guide should be read in conjunction with The Taxi Licensing Regulations (Northern Ireland) 2015, The Taxi Accessibility Regulations (Northern Ireland) 2015 and the Taxi Inspection Manual.

It will be applied to the vehicle at the time of its initial taxi licensing assessment. This guide may also provide customers with advanced knowledge of the DVA's taxi inspection criteria.

The Detail

Vehicle length

All taxis must be a minimum of 3.96m in length. There is no maximum vehicle length other than what is quoted in the Construction and Use Regulations.

Tyre loads

Where quoted, record the axle weights and tyre load indices on the Inspection Report (TL4), having confirmed that the tyres are suitable for the vehicle weights.

Steering wheel

The steering wheel must be on the right hand side of the vehicle when viewed from a forward facing front seat

Intercom and Induction Loop systems

(not applicable to a taxi licensed in the 12 months preceding 31/5/16)

For vehicles with a partition between the driver and rear passenger compartment, an Intercom and Induction Loop system must be fitted and signage must be displayed to inform passengers of the systems availability

Internal lighting

(not applicable to a taxi licensed in the 12 months preceding 31/5/16)

Internal lighting must be available to illuminate the wheelchair space, as required

Steps

The maximum distance from the ground to the top tread of the lowest step of every passenger entrance or exit on a vehicle must not be more than 435mm (see 'Accessibility step etc.' below). For the tread area (area on a vehicle that is immediately below a closed door), to be regarded as a suitable step/platform, it **must** be capable of supporting and assisting a passenger to safely alight from the vehicle.

Where the original step/platform of the entrance or exit exceeds 435mm from the ground (measured at the highest point on the vehicle where a passenger's foot would have to cross whilst entering/exiting) an additional fixed step (includes a retractable/folding step) must be provided at each passenger entrance or exit.

A step must not project beyond the body of the vehicle, unless it can be repositioned so as not to extend beyond the body whilst the vehicle is in motion. This requirement does not apply to a vehicle fitted with a step supplied by the vehicle manufacturer as original equipment, provided all other step requirements are met. Electrically operated steps must be capable of being controlled from the driver's seat.

NB: A fixed step is acceptable if it extends beyond the body of the vehicle, but is retained within the width of a folded mirror, provided that mirror has been fitted at the time of the vehicle's manufacture.

- Each step must be a minimum of 95mm in width and have the tread area covered in a slip-resistant material.

It is not necessary for the full 95mm step width to project outwards beyond the sill of the vehicle; it is acceptable for not more than 20mm of the step to be 'inset' from the outer edge of the sill, provided the complete step is sufficient to accommodate a person's heel. However, it is important to note that where the step is used to exit from the 3rd row of the vehicle, the full 95mm step width must project outwards beyond the sill.

- Where a vehicle is fitted with a retractable/folding step, the vehicle must have an automatic warning device fitted to it (buzzer or warning lamp) to warn the driver that the step is deployed.

- There must be a band of colour of between 45-50mm across the front edge of each step, and the band of colour must contrast with the remainder of each step.
- Each step must be soundly and properly constructed and fitted in such a manner that it is unlikely to injure a passenger or other road user.

Accessibility step etc.

(not applicable to a taxi licensed in the 12 months preceding 31/5/16)

1 In addition to the step requirements mentioned above, all passenger steps must not exceed 435mm in height and an Accessibility Step is required on at least one passenger entrance on the nearside if any passenger step exceeds 380mm.

Where a step is fitted to meet this requirement, it must be:

- A minimum of 400mm in length
- A minimum of 200mm deep (when in use, project at least 200mm outwards beyond the outer sill)
- Covered in slip resistant material
- Displaying a band of contrasting colour, at least 50mm wide, around each of the external edges
- As above, a retractable/folding step must be fitted with an automatic warning device (buzzer or warning lamp) to warn the driver that the step is deployed.

The entrance/exit fitted with this Accessibility step must also be fitted with at least one handhold or hand rail, which is:

- Covered in a slip resistant surface
- Capable of being easily and firmly gripped
- In a colour that contrasts with the surrounding parts of the taxi.

Note: An Accessibility Step is not required where all passenger steps are at a height of 380mm or less.

Handholds and Handrails

Where a passenger steps into a vehicle other than directly from the ground, a handhold or handrail may be provided, where necessary, to assist passengers to safely access or egress the vehicle. All handholds and handrails must be capable of being easily and firmly gripped. Examiners are advised to pay particular attention to the need for handholds, where the minimum step width only, is provided.

Permanent Top (roof)

All vehicles must be fitted with a permanent top (roof) *i.e.* the roof is not capable of being positioned to completely uncover all seats.

Doors

All vehicles must have at least four doors, two of which must be located on each side of the vehicle. Passenger doors must be capable of being readily opened from the inside and outside of the vehicle by one operation of the latch mechanism, and must be capable of being opened independently from each other.

Luggage

When all passenger seats are occupied, the vehicle must have a luggage capacity of 80 litres; the luggage space should be separate from the passenger's compartment and be broadly equivalent to two small-medium sized 'carry-on' suitcases.

For vehicles that have a 3rd row of passenger seats (MPV/ people carrier) the required luggage space may be achieved by folding the 3rd row of seats, provided there is no obvious risk to passenger safety (examiners must continue to include the 3rd row of seats when determining the maximum passenger capacity).

Examiners are advised to use discretion when assessing the luggage space.

N.B. The luggage capacity for most unmodified vehicles may be obtained from manufacturers' sales brochures or through internet searches which may be relied upon for assessment purposes.

Where the luggage compartment is used to accommodate the spare wheel (e.g. an LPG tank has been located in the spare wheel well), a volume of 35 litres may be assumed for the spare wheel. Therefore, the luggage compartment must be assessed capable of carrying the 35 litre spare wheel, plus 80 litres of luggage.

Other acceptable methods of achieving the luggage capacity:

- A roof-rack
- An open boot lid that is capable of providing a safe and secure luggage carrying platform (the number plate must be easily read when the boot lid is used for this purpose)

- Where a partition is fitted between the driver and rear passenger compartment, the front passenger seat can be tipped-up to provide the required luggage space (any luggage carried must be capable of being safely secured).

Wheelchair storage

(not applicable to a taxi licensed in the 12 months preceding 31/5/16)

A space measuring at least 735mm x 330mm x 805mm must be available to accommodate a folded wheelchair. This space must provide for the wheelchair to be secured safely, and may be located within the passenger compartment, provided there are no obvious risks to passenger safety.

Seating

Seating assessment involves a range of elements that must be considered simultaneously:

1. Cushions
2. Contoured seating
3. Width of seats (including folding seats)
4. Retractable/fold-up armrests
5. Access to the rearmost row of seats (including MPV's)
6. Protrusions in the passenger compartments
7. Leg room
8. Headroom

Examiners are advised to position the seats in compliance with the minimum dimensions recorded at the Annex, prior to assessment, and to note that it is acceptable for the back rest of any seat to be positioned not more than 90 degrees from the horizontal plane.

Cushions

All seats must be properly cushioned and upholstered in cloth, leather or artificial leather. All cushioned seats must provide reasonable comfort for passengers

Contoured seating

The space between two contoured seats may be assessed suitable as a seat when it complies with all of the above requirements, including the requirement for reasonable passenger comfort.

Width of seats (including folding seats)

The width of every allocated passenger seat shall be **at least** 400mm, and

- A continuous seat accommodating 3 passengers must have a minimum dimension of 1200 mm measured across the front edge of the seat cushion. In addition, there must be a minimum dimension of 1300mm measured around 150mm forward of and parallel with the seat back, at a height 600mm above the uncompressed seat cushion (passenger shoulder location); a back rest measuring less than 1300mm may be accepted (see the Annex dimensions for E, F and G).
- The depth of any passenger seat cushion (distance between front edge of seat cushion and the seat back rest) must be assessed on an individual basis as related passenger comfort is interdependent on available leg room.

Retractable/fold-up armrests

When assessing the suitability of a seat backing incorporating an integrated arm rest, examiners must ensure that the seat back provides adequate passenger comfort when the arm rest is in the raised position.

Access to and from the 3rd row of seats, where all vehicle seats are forward facing

There are several elements to the assessment of the 3rd row of forward facing seats, all of which must be considered simultaneously and ultimately considered capable of providing passengers with reasonable access/egress without assistance.

Access and egress must be provided to both side doors only, and can be accepted if achieved by:

- Removal of one outer seat or the centre seat, in the 2nd row of seats to provide a suitable and safe access, or
- Tilting of the seats on the 2nd row to provide safe and reasonable access to the 3rd row of seats; *when exiting from the 3rd row, a passenger must be capable of*

*positioning the seats to afford reasonable access to all side doors in the passenger compartment. The instructions for moving the seats must be clearly marked on the back **and** side of the seats as appropriate (a pictogram providing clear instruction is acceptable).*

When considering seat access the examiner must also consider:

- The size and suitability of the passage-way when the 2nd row seats are displaced
- Hand holds that may be required to assist a person when exiting from the 3rd row of seats
- Suitability of steps

Not more than a double seat may be tilted to provide a suitable passage-way/access to the side door. The examiner shall decide if the type of seats are acceptable; there are two different types of seat systems for consideration, however, **where any of the outer seats in the 2nd row of seats have seatbelt systems that require the belts to be disconnected from the seat to allow the seat to tilt, this seat system is considered unacceptable:**

Note: it is not acceptable to have detachable seatbelts fitted to the outer seats in the second row, where their fitment prevents reasonable access/egress to the 3rd row.

- Standard seating provided in mass produced vehicles are considered acceptable (provided the seatbelt system complies with the above requirements and all seating and interior dimension requirements are met) and where the tilted seats expose fixtures in the flooring; these should be ignored for assessment purposes.
- Alternative type approved seating; It is impossible to make a blanket judgement on this type of seating, as they can be so varied they can only be assessed on an individual basis. The examiner's decision will be based on a passenger who is not familiar with the vehicle being able to understand the process of how to tilt the seat (the complexity of the tilting mechanism) and the ease in which it tilts (the weight of the seat).

The passage-way to the door aperture must be of an adequate size to allow a person to access the doorway. At the doorway, a **departure area** must be provided to allow a person to stabilize themselves before exiting safely from the vehicle.

If the departure area is not capable of accommodating both of the passenger's feet at the same time, suitable **handholds must be provided** to ensure that a person can stabilize themselves before and during the exiting process.

Where the departure area is in a lowered 'footwell' the datum for the maximum step height measurement of 435mm (for vehicles not licensed during the 12 month period preceding 31/5/16 - 380mm at the 'Accessibility step') shall be taken from the highest edge where a foot would have to cross whilst entering, or departing from, the vehicle.

The 'departure area' is a rectangular space to simulate an area where a passenger could stand with both feet side by side prior to departure from the vehicle; it should be predominantly flat and have a minimum dimension of 300mm x 200mm, the smaller side (200mm dimension) shall be between parallel and 45 degrees from the door aperture and the same side shall be not more than 200mm from the outside edge of the vehicle.

Leg room

The following minimum leg room requirements must be available to ensure reasonable passenger comfort:

- There must be a space of at least 275mm measured between the vehicle floors and the top foremost/centre edge of each uncompressed seat cushion (see the Annex dimension C), this requirement does not apply where the presence of a transmission tunnel reduces the leg room.
- There must be a clear space of at least 630mm measured longitudinally from the lowest central position of each passenger back rest (see the Annex dimension A).
- There must be a clear space of at least 200mm measured longitudinally from the foremost edge of each passenger seat cushion (see the Annex dimension D); this requirement does not apply to any area directly above a transmission tunnel. In addition, the 200mm clear space requirement may be reduced to 150mm, where a centre console (located between the front seats) protrudes into the rear passenger compartment.
- There must be a space of at least 400mm measured between the foremost edges of each opposing passenger seat cushion.
- Where a passenger's legs are required to straddle the transmission tunnel, that tunnel must not exceed 300mm in width at its highest point.

Headroom

There must be a minimum height of 880mm measured vertically from the lowest central position of each uncompressed passenger seat cushion to the head cloth (see the Annex dimension B)

Wheelchair entrance

(not applicable to a taxi licensed in the 12 months preceding 31/5/16)

The entrance/exit designated for the wheelchair user must have a minimum unobstructed height of 1235mm a minimum unobstructed width of 750mm. The occupied wheelchair must have unobstructed access to and from the wheelchair space.

Boarding Ramp

(not applicable to a taxi licensed in the 12 months preceding 31/5/16 – see Note below)

A boarding ramp or lift must be available to assist with the loading of an occupied wheelchair. Where a boarding ramp is fitted and is deployed it shall be:

- Located at the nearside or rear of the vehicle
- Capability of being secured to the vehicle to prevent slipping or tilting when in use
- A minimum of 700mm in width and have a single continuous surface
- Devoid of any sharp edges or protrusions likely to cause a danger
- Sloping at not more than 16° when secured to the vehicle, with the outer edge resting on a block 125mm in height (to simulate a kerb)
- Displaying a band of contrasting colour, at least 50mm wide, around each of the external edges
- Capable of being safely stored and readily available for use

Note: For taxis licensed in the 12 months preceding 31/5/16 – a boarding ramp or lift must be fitted and assessed as unlikely to cause a foreseeable danger; the device must not slip or tilt when in use and must be capable of being safely stowed.

Boarding Lift

(not applicable to a taxi licensed in the 12 months preceding 31/5/16)

Where a boarding lift is fitted it must comply with BS EN1756-2. Examiners are advised to accept that this requirement has been met on M1 type approved Wheelchair Accessible Vehicles (WAVs), unless the lift is obviously unsafe, or has obvious obstructions preventing access to the wheelchair space.

Occupied Wheelchair Space

Taxi not previously licensed and being licensed for the first time from 31/5/16 - the vehicle must be capable of accommodating either a forward or rearward facing occupied wheelchair, having dimensions of 1200mm in length, 700mm in width and 1350mm in height.

Taxi licensed in the 12 months preceding 31/5/16 (with the exception of those previously licensed as Belfast Public Hire, which can be assumed as meeting equivalent wheelchair space requirements) – the vehicle must be capable of accommodating either a forward or rearward facing occupied wheelchair, having dimensions of 1200mm in length, 700mm in width and 1200mm in height.

NB: An occupied wheelchair would not utilise the entire wheelchair space, therefore certain protrusions into that space may be acceptable where the examiner is content that the occupied wheelchair can be manoeuvred and secured into the space.

Displacing Seats

The detachment and relocation of a passenger seat/s is **only** accepted for the purpose of providing a wheelchair space. The following conditions must be met:

- Detached seats must be moved to a safe storage location **in the taxi**, where they cannot be used by a seated passenger
- Only **single** type passenger seats (original fitment or bespoke) may be detached and relocated in the taxi e.g. it is not acceptable for a double or triple passenger seat to be detached and relocated.
- Detachable seats (original fitment or bespoke) must be capable of being quickly released, where no tools are required to either detach the seat or secure the seat in its stored location, minimising any unnecessary delay
- Seats that have been moved to provide a wheelchair space **must** be readily secured in the taxi (ratchet straps are recommended), where **no** exits are

blocked from use by other seated passengers in that compartment, and where there is no obvious risk to passenger/driver safety.

Alternative, for rear loading wheelchair only, where it is not practical to relocate the seat/s to a position where all exits in the compartment remain unobstructed, it is acceptable for a detached seat to be located to a position where it is blocking an exit in the compartment, provided the following conditions are met:

- the wheelchair entrance remains unobstructed, and
- the only passenger carried in that compartment is the wheelchair passenger (no passenger seats in that compartment may be used for that journey).
- Seats that have been moved to provide the wheelchair space must be assessed in their licensed seating location and in their stored location during the vehicle's Initial Assessment, to confirm there are no obvious risk to passenger/driver safety.
- Relocated seats must not reduce the mandatory luggage capacity of the taxi

Dedicated Wheelchair Space (space suitable for an occupied wheelchair only)

Where the vehicle has a dedicated wheelchair space (space complies with the dimension requirements referred to above, and is **not** fitted with a passenger seat that may be used in the absence of an occupied wheelchair (e.g. fold down seat) - the examiner must record the number of dedicated wheelchair spaces and the number of passenger seats, separately on the test hall system (e.g. 2 wheelchair passengers, and 6 seated passengers).

NB: The combined total of wheelchair passengers and seated passengers must not exceed 8. The number of wheelchair passengers and the number of seated passengers will also be recorded separately on the Taxi Licence.

Note: Where an occupied wheelchair obstructs the access from a passenger seat to all exits in the compartment, that seat must not be used when the wheelchair is carried, but is still counted when calculating the maximum seating capacity. In these circumstances, the wheelchair space is **not** considered to be a dedicated wheelchair space.

Wheelchair anchorages and restraint Systems

Forward facing wheelchair: with the exception of taxis previously licensed in the 12 months preceding 31/5/16, the system must comply with BS10542. In all cases, have a minimum of 4 wheelchair anchorage points with belts attached that are capable of safely securing the wheelchair in a forward facing position (alternatively, the wheelchair may be secured using a tracking and clamp system, or a docking station system). The wheelchair occupant restraint system must have 3 anchorage points (2 lower anchorage points having a minimum separation distance of 300mm, and 1 upper anchorage point not less than 1100mm in height) and a 3 point seatbelt, capable of safely securing the passenger in a forward facing position (it is acceptable for the same anchorage point to be used to secure a wheelchair restraint belt plus an occupant restraint belt). Vehicles not previously licensed and being licensed for the first time from 31/5/16 will be type approved as a WAV, therefore it may be accepted that the BS 10542 requirement has been met, provided all specified anchorages and belts are present and serviceable.

Rearward facing wheelchair: As the vehicle must be type approved with an integral partition-based restraint system incorporating the wheelchair and wheelchair occupant restraints, it is accepted that the system, as presented, offers an equivalent level of safety to that of a forward facing wheelchair system. However, this system may have less than 4 wheelchair anchorage points and less than 3 wheelchair occupant anchorage points.

The Annex

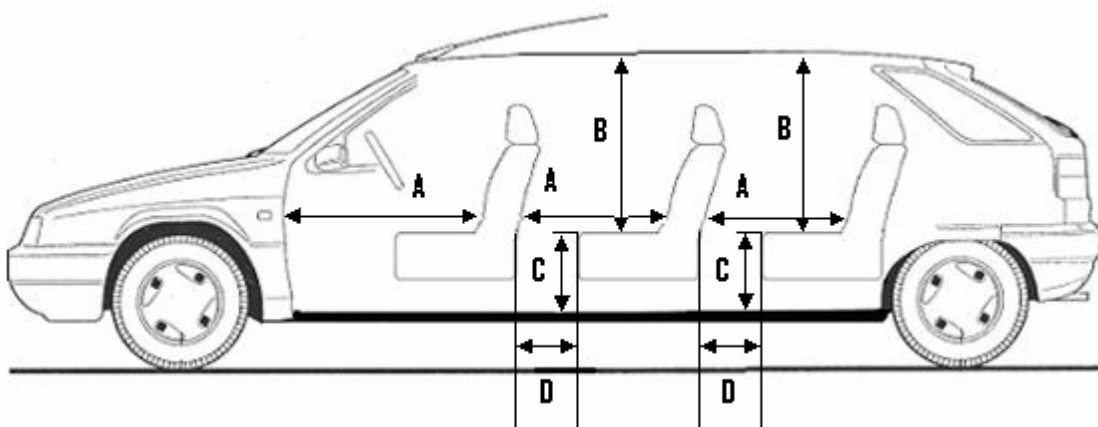

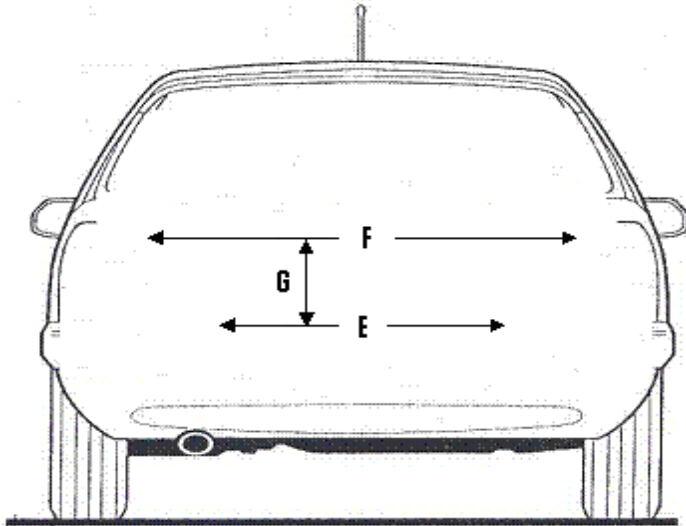

<u>Dimension</u>	<u>Description</u>	<u>mm</u>
A	Front seat minimum dimension between the seat back cushion and the dash	No minimum requirement
A	Minimum distance between seat back and seat cushion rearward of it	630
B	Minimum headroom	880
C	Minimum height of seat squab; Cushion not compressed	275
D	Minimum distance for leg room	200
E	Minimum width for 3 continuous seats	1200
F	Minimum width for 3 passengers at shoulder height	1300
G	Distance between seat cushion and shoulder height dimensions	600

[Back to Index](#)

Record of Revision

Revision	Date	Description of Change
1	04/05/2018	Add text concerning, all Taxis fitted with a 3 rd row of seats must be marked with operating instructions, or display a pictogram, they should be readily understood. Passengers must have unobstructed access to two doors, however one door may be obstructed.
	05/01/2023	Document reviewed January 2023 no changes made.
2	28/04/2026	Document reviewed April 2026 changes made to the Seating and Passenger Capacity section – All passenger seats suitable for licencing must be counted - paragraph updated.