

BRAKE SYSTEMS AND COMPONENTS

APPLICATION

This inspection applies to all vehicles and trailers.

PROCEDURE AND STANDARDS

Brake Components

Check the condition, security and operation of brake rods, relays, levers, including slack adjusters, clevis joints, linkages, cables, flexible and rigid pipes.

Check the condition and security of brake drums, back plates and shoes, discs, callipers, pads including friction material.

Note:

- A rod or lever reduced by more than one third of its original diameter is considered a failure.
- A pipe with its wall thickness reduced by more than one third of its original thickness is considered a major or dangerous deficiency depending upon severity.
- Cables, less than 10% of the wires fractured is not regarded as a reason for failure unless there is bunching, or likelihood of bunching, where the cable enters an outer cable, guide or sleeve (cables are usually made up of strands each containing a number of wires).
- A hose should be rejected for surface cracking or damage by chafing only if the reinforcement is visible.
- Repairs to metal air brake pipes by sleeving are acceptable, providing the repair appears to be good and sound. A pipe repaired in-situ by brazing is not considered acceptable. Repairs to hydraulic brake pipes are not acceptable. Compression joints of the type using separate ferrules are not considered suitable for joints on hydraulic pressure lines.

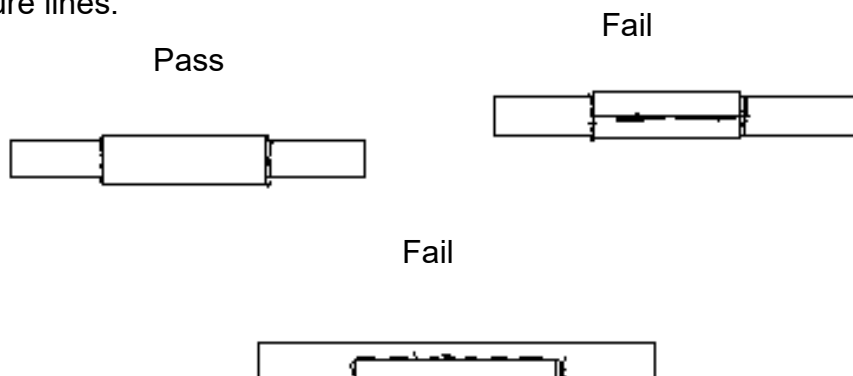

Guidance on sleeved repairs of metal brake pipes (sleeving is not acceptable on plastic brake pipes).

- The air pipe between the compressor and the reservoir is to be taken as a brake pipe.
- Slack adjusters; up to 9.5 mm radial movement at a radius of 150 mm is considered acceptable within the slack adjuster and between the slack adjuster and cam cross shaft. Slack adjusters must have a secure fastening to the cross shaft including a locking device
- Check that automatic slack adjusters are fitted to vehicles and trailers on which they are mandatory (Trailers manufactured and vehicles first used on or after 1st May 1997) and check presence, condition and security of control brackets for all vehicles fitted with lever type automatic slack adjusters.
- Check and compare travel of automatic slack adjusters across the same axle when service brakes are applied, and check that automatic slack adjuster levers return fully when brakes are released.

Disc Brakes

The diagram below shows the type of damage which is likely to be found on brake discs and gives guidance on how much damage is acceptable before failing the vehicle. This should be a visual assessment.

- A. Interlinked cracks or surface crazing = acceptable
- B. Cracks running towards hub centre up to max 75% of the width of the friction surface, and a maximum of 1.5mm wide or deep = acceptable
- C. Unevenness in the disc surface less than 1.5mm = acceptable
- D. Cracks running from edge to centre = not acceptable

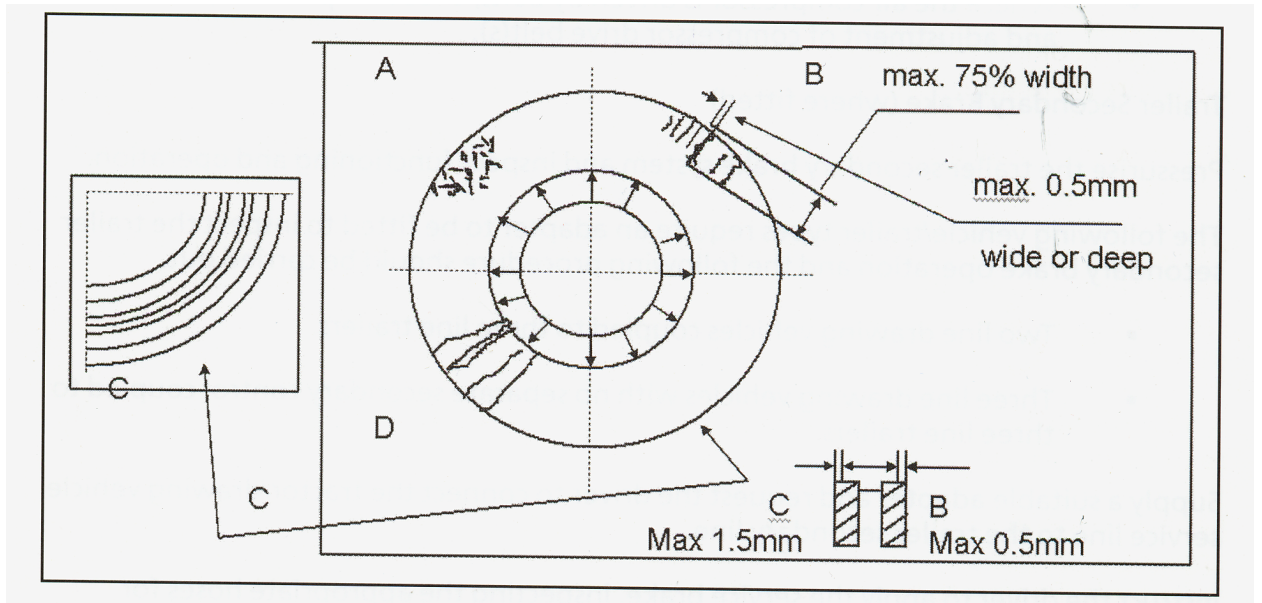

Reservoirs (The term reservoir includes accumulators and other types of vacuum & pressure vessels).

- Check for condition, security and leaks.

Brake Actuators, Hydraulic Master & Wheel Cylinders, Valves and Servos.

- Check for operation, condition, security and leaks.

Damp patches around valves or adjacent components are not a Reason for Failure. Only where there is evidence of heavy discharge of oil from the valve at the time of test should there be a failure.

Note:

To check the condition of brake pipes, valves, hydraulic master & wheel cylinders it will be necessary to ask the other examiner to pressurise the braking systems. There is no requirement for a specific check on the operation of all valves, however where it is obvious that a valve is malfunctioning during any stage of the test, this is a Reason for Failure.

When assessing the significance of leaks, it should be remembered that certain pneumatic components are subject to leakage to some degree.

Vented master cylinders as fitted in particular to some Bedford vehicles may be subject to some dampness around the vent, due to fluid in the bores of the cylinder used to lubricate the piston seals, this should not be treated as a defect.

Hydraulic brake fluid and fluid level checks are confined to transparent reservoirs or where an indicator is fitted. Reservoir caps should not be removed.

Load Sensing Valves: Vehicles first used before 1 April 1983 should not be failed where a load-sensing valve has been removed.

There are many types of load sensing valves fitted to vehicles, employing different methods of operation. Care must therefore be exercised when deciding if a valve is defective or not.

Certain vehicles with anti-lock braking systems or which otherwise comply with the requirements of the Brake Directive do not require load sensing valves. e.g. Municipal vehicles or vehicles with a high unladen weight in comparison with the laden weight.

Missing or illegible Load Sensing Valve (LSV) plate only applies to the following;

Trailers manufactured on or after 29th October 2013

Trucks first used on or after 29th October 2014

Quick Release Valves/Spring Brake Systems;

On trailers fitted with spring brake systems a controlled discharge of air may occur from the quick release valve when the service brake is applied with the spring brakes in the off position, this is acceptable and should not be treated as a defect.

Goods vehicles and Trailers in excess of 3500 KGs GVW used on or after 1 May 1997, must have an automatic means of wear adjustment on the service brake system.

Air Compressor Drive

- Where belts drive the air compressor, check for presence, condition and adjustment of compressor drive belt(s).

Supply Dump Valve

The operation of the Supply Dump valve on drawing vehicles should be checked during the annual inspection. Ensure air braking system is fully charged, the combination is chocked and the trailer park brake is released. Switch off ignition, disconnect the service (yellow) brake line and vent to atmosphere, fully apply the service brake, air will vent for a few seconds before stopping and bringing the trailer brakes on. Where this does not happen the vehicle should be failed under Notice of Refusal 5a.

Note: - It is important that the ignition is switched off before checking the operation of the dump valve on all vehicles. Vehicles fitted with EBS may log a fault in the vehicle's ECU and illuminate a MIL if the ignition is switched on. **Some** vehicles will automatically apply the park brake when the ignition is switched off; on most vehicles the park brake being applied does not prevent the checking of the supply dump valve operation. However **Renault Trucks** which automatically apply the parking brake when the ignition is turned off, also pressurise the service (yellow) line to the trailer. These vehicles must have the parking brake released by the following process before checking the operation of the supply dump valve:-

With the ignition turned off and the parking brake automatically applied,

1. Turn ignition switch to the **first position** (auxiliary),
2. Apply the foot brake pedal and hold,

3. Release the parking brake, holding the park brake switch in the off position for a few seconds until the parking brake releases,
4. Release foot brake,
5. Conduct supply dump valve check as normal, but with ignition switch at the auxiliary position instead of completely switched off.

Trailer Parking Brake

The operation of the parking brake must be tested before uncoupling with all air lines connected:-

Mechanical brakes i.e. ratchet/screw type, apply the parking brake and observe the movement/operation of all relevant components.

Air/spring type, pull the park button to exhaust air from brake chambers, and observe the movement/operation of all relevant components (there is no specific time period for the air to be fully exhausted). Request the driver to attempt to shunt the vehicle forward, observe that all relevant brakes are applied.

Note: - It is essential that the trailer parking brake is applied before uncoupling.

Trailer secondary Brake (where fitted)

Pressurise the trailer secondary brake system and inspect functioning and operation. (This should be carried out when checking the self-sealing couplings).

The following vehicle/trailer type require an adapter to be fitted to inspect the trailer secondary operation and the following procedure should be carried out

Two line drawing vehicles coupled to three line trailers.

Three line drawing vehicles with no separate secondary control coupled to three lined trailers.

Using a suitable adapter, connect the tractor/drawing vehicle service line to the trailer secondary line.

Instruct the driver to apply the service brake, inspecting the appropriate hoses and system operation.

Note:

If spring brake actuators are fitted to the vehicle/trailer inspect the components of this system with the parking brake in the "off" position.

Remove the adaptor and connect the brake lines. Check the reconnection by instructing the driver to apply the footbrake and note the operation.

Note; Care should be taken when inspecting axles manufactured by BPW, as the brake calliper may have 6 holes and only 5 bolts fitted.

Note: Hydraulic fluid reservoir level checks are confined to transparent reservoirs or where an indicator is fitted. Reservoir caps should not be removed.

REASONS FOR FAILURE

	Deficiency Category
Brake Components	
1. A brake rod, clevis joint, linkage, relay, lever, slack adjuster or cable:	
a. Seriously weakened by excessive wear, corrosion or damage or reduced in diameter by more than the prescribed limit..	MAJOR
b. With abnormal movement indicating incorrect adjustment or excessive radial free play.	MAJOR
c. With an ineffective, insecure or missing locking device.	MAJOR
d. A brake cable knotted, or with more wires broken than permitted by the specified standard.	MAJOR
e. A brake cable knotted, or with more wires broken than permitted by the specified standard which obviously affects the braking performance.	DANGEROUS
f. Cable guide is defective	MAJOR
g. Automatic slack adjuster component incorrectly installed, missing, disconnected, insecure, distorted, fractured or inoperative.	MAJOR
h. Brake system not fitted with a means of Automatic wear adjustment where required.	MAJOR
i. A brake fitted with an automatic slack adjuster exceeding two-thirds of the travel of the brake actuator, or obviously having a different travel from another brake on the same axle, or not returning fully when brakes are released.	MAJOR
2. Brake pipes and flexible hoses:	
a. Misplaced and fouled or chafed by moving parts, with no obvious damage evident.	MINOR
b. Misplaced and fouled or chafed by moving parts with	MAJOR

- obvious signs of damage.
- | | | |
|----|--|-----------|
| c. | Chafed, cracked and no reinforcement cords exposed, corroded, stretched or twisted. | MINOR |
| d. | Excessively chafed, cracked with reinforcement cords exposed and damaged, excessively corroded, deteriorated, | MAJOR |
| e. | Excessively chafed, cracked with reinforcement cords exposed, excessively corroded, deteriorated, leaking, bulging, kinked, stretched or twisted and damage evident. | DANGEROUS |
| f. | Leaking, bulging, kinked, stretched or twisted and in such a condition that risk of failure is imminent. | MAJOR |
| g. | Inadequately clipped or otherwise inadequately supported. | MAJOR |
| h. | Inadequately repaired or with unsuitable joint fittings. | MAJOR |
| i. | Non-metallic pipe(s) exposed to excessive heat. | MAJOR |
| j. | Leaking air from a pipe or connection. | MAJOR |
| k. | Leaking hydraulic fluid from a pipe or connection. | DANGEROUS |
| 3. | Brake drums, back plates & shoes, discs, callipers, pads including friction material with: | |
| a. | A brake disc or drum excessively worn. | MAJOR |
| b. | A brake back plate, disc or drum in such a condition that it is seriously weakened or insecure. | DANGEROUS |
| c. | A brake back plate or calliper securing bolt loose or missing. | MAJOR |
| d. | A brake lining or pad less than 1.5mm thick at any point. | MAJOR |
| e. | A brake lining or pad, missing, incorrectly fitted, insecure or with the lining no longer visible. | DANGEROUS |
| f. | Restricted movement of a brake component. | MAJOR |
| g. | A brake drum, disc, lining or pad contaminated by oil or grease. | MAJOR |

h.	A brake drum, disc, lining or pad contaminated by oil or grease with the brake performance obviously affected.	DANGEROUS
i.	A brake disc excessively worn, scored, pitted, or brake contact area significantly reduced.	MAJOR
4.	Reservoirs:	
a.	Lightly corroded	MINOR
b.	Insecure, excessively corroded, or leaking.	MAJOR
c.	With damage or dents that do not reduce the capacity.	MINOR
d.	With damage or dents that obviously reduce the capacity.	MAJOR
e.	With a securing strap fractured, cracked, excessively corroded or chafing on the reservoir or other mounting.	MAJOR
f.	Missing where it is known to be a standard fitting.	MAJOR
5.	Air actuators, hydraulic master & wheel cylinders, valves & servos:	
a.	Defective in operation.	MAJOR
b.	Defective in operation and brake performance affected.	DANGEROUS
c.	Insecure but still operational.	MAJOR
d.	Insecure and brake performance affected.	DANGEROUS
e.	Leaking air or fluid, fractured, cracked, excessively damaged or corroded.	MAJOR
f.	Leaking air or fluid, fractured, cracked, excessively damaged or corroded and brake performance is affected.	DANGEROUS
g.	With a locking device missing or insecure.	MAJOR
h.	With insufficient or excessive travel of operating mechanism indicating a need for adjustment.	MAJOR
i.	With insufficient or excessive travel of operating mechanism indicating a need for adjustment and brake performance is affected.	DANGEROUS

- | | | |
|----|--|-----------|
| j. | With a cap missing from a hydraulic master cylinder. | MINOR |
| k. | Fluid below minimum level or level warning device defective/activated. | MINOR |
| l. | Fluid significantly below minimum level. | MAJOR |
| m. | No brake fluid visible. | DANGEROUS |
| n. | Brake fluid contaminated | MAJOR |
| o. | With a valve with excessive discharge of oil. | MINOR |
| p. | A load sensing valve removed or disconnected when it is known to be a standard fitment. | DANGEROUS |
| q. | A load sensing valve obviously seized or restricted in its free movement, linkage or brackets cracked, defective or out of adjustment (ABS functioning). | MAJOR |
| r. | A load sensing valve obviously seized or restricted in its free movement, linkage or brackets cracked, defective or out of adjustment. (No ABS function). | DANGEROUS |
| s. | Hydraulic brake actuator dust cover damaged or deteriorated but not to the extent that it would no longer prevent the ingress of dirt etc. | MINOR |
| t. | Hydraulic brake actuator dust cover missing, insecure, excessively damaged or severely deteriorated to the extent that it would no longer prevent the ingress of dirt etc. | MAJOR |
| 6. | A load sensing data plate is missing or illegible. | MINOR |
| 7. | Air Compressor Drive: | |
| a. | A drive belt missing, badly deteriorated and/ or so loose that it is likely to slip. | MAJOR |
| b. | A compressor drive pulley loose, cracked or missing. | MAJOR |
| 8. | Trailer Secondary Brake defective in operation. | MAJOR |
| 9. | | |

- a. Unsafe modification to any part of the braking system. MAJOR
- b. Unsafe modification to any part of the braking system and braking performance is affected. DANGEROUS