

# SEAT BELT, ANCHORAGE POINTS AND RESTRAINT SYSTEMS

## APPLICATION

This inspection applies to all buses which have seat belts fitted.

The inspection of Supplementary Restraint Systems (SRS) applies to airbags, seat belt pretensioners and seat belt load limiters when fitted as standard.

## PROCEDURE AND STANDARDS

Certain buses require seat belts regardless of their use (Obligatory belts). These are shown below along with the seat belts which are required. These must be checked to ensure that seat belts are fitted to the seats on which they were determined to be needed at the time of certification

Seat belts may be fitted to all types of minibuses, buses and coaches, both single and double decked, and may be in addition to those required in the tables at the end of this section. It will not be necessary to carry out the installation check unless extra belts have been fitted since the last test, but the condition check must be carried out on all belts and fittings on the vehicle.

Minibuses with 9-12 seats and first used before 1 October 1990.

Date of first use	Seat position	Type of belt
From 1 January 1965 to 31 March 1982	Driver's and any specified passenger's seat	Three point adult belt or body restraining belt.
From 1 April 1982 to 30 September 1990	Driver's and any specified passenger's seat	Three point adult belt.

Minibuses (not exceeding 3500kg design GVW) and Coaches first used from 1 October 1990 until 31 August 2002.

Seat Position	Minibus (not exceeding 3500 kg gross weight)	Coach
Driver's	Three point adult belt. Must be able to be locked and released by single action. (Exemption for disabled drivers)	Three point adult belt or a lap belt designed for an adult or a disabled person's belt. Must be able to be locked and

		released by single action. (Exemption for disabled drivers)
Specified passenger's	Three point adult belt. If alongside the driver must lock and release with a single action	
Any other foremost forward facing front seat	Three point adult belt or a lap belt designed for an adult.	Three point adult belt or a lap belt designed for an adult or a disabled person's belt.
Other forward facing (not protected by high back seats) and crew seat(s)		Three point adult belt or a lap belt designed for an adult or a disabled person's belt.

Buses, coaches and minibuses first used from 1 September 2002. which are not authorised to carry standing passengers.

Seat Position	Not exceeding 3500 kg design gross weight	Exceeding 3500 kg design gross weight
All forward and rearward facing seats including the driver's seat	<p>An inertia reel 3 point belt or</p> <p>A retractable lap belt (on rearward facing seats only) or</p> <p>A disabled person's belt or</p> <p>A child restraint</p> <p>Seat belts for the driver and specified passenger along side the driver must be able to be locked and released with single action. (Exemption for disabled persons belt)</p>	<p>An inertia reel 3 point belt or</p> <p>A retractable lap belt or</p> <p>A disabled person's belt or</p> <p>A child restraint</p> <p><b>BUSES</b></p> <p>Seat belts for the driver and specified passenger along side the driver must be able to be locked and released with single action. (Exemption for disabled persons belt)</p> <p><b>COACHES</b></p> <p>Driver's seat belt must be able to be locked and released with single action. (Exemption for disabled persons belt)</p>
On vehicles constructed for the	An inertia reel 3 point	An inertia reel 3 point

secure transport of prisoners the driver's seat and any seat for front seat passengers	Seat belts for the driver and specified passenger along side the driver must be able to be locked and released with single action. (Exemption for disabled persons belt)	Seat belts for the driver and specified passenger along side the driver must be able to be locked and released with single action. (Exemption for disabled persons belt)
--	--	--

**Note:**

A harness belt may be used as an alternative to a three point or lap belt. The requirement for a buckle to lock with a single action does not apply to harness belts.

**Note:**

Coach; a large bus over 7500 kgs GVW with a maximum speed exceeding 60 mph.

Seat belts may be fitted to all types of minibuses, buses and coaches, both single and double decked, and may be in addition to those required above.

**CONDITION INSPECTION OF ALL SEAT BELTS FITTED**

As far as it is practicable without dismantling, check the condition of the vehicle structure around the seat anchorage point (i.e. within 300mm of the anchorage). Where a seat belt is mounted to a seat frame this will apply to all seat mounting points. The floor-mounted anchorage points might need to be inspected from underneath the vehicle.

Pull each seat belt webbing against its anchorage to see that it is properly secured to the vehicle structure.

**Note:** For seats with integral seat belts, it might not be possible to examine the fixing of the seat belt to the seat.

Fasten each belt locking mechanism and then try to pull the locked section apart. On retracting seat belts, check that with the mechanism fastened and the seat unoccupied, excess webbing is wound into the retracting unit.

**Note:** Some types of retracting belts might need manual help before they retract. Operate the release mechanism while pulling on the belt to check that the mechanism releases as required.

Examine flexible buckle stalks for:

- a) Signs of corrosion or weakness. Pull the sheaths aside, if this can be done without damage.
- b) 'waggle' flexible buckles and listen for a clicking noise indicating broken strands of cable.

Examine the condition of all seat belts webbing for cleanliness, cuts or obvious signs of deterioration. Pay particular attention to webbing around anchorages, buckles and loops.

Examine the condition of the attachment fittings and adjusting on each belt.

Check the seats to which seat belts are attached for security and for cracks or fracture of the leg and frame.

**Note:** Some vehicles have seat belts which will not release the inertia aspect of the seat belt unless the ignition is switched on. Ensure the park brake is applied and the gears are in the neutral position before switching on the ignition. Owing to the height of cabs on many commercial vehicles this inspection should be performed with the inspector sat in the appropriate seat.

**Note:** Floor mounted anchorages may need to be inspected from underneath the vehicle.

### **INSTALLATION INSPECTION**

All belts should be checked for installation, operation and wear. The following categories shall only be checked for operation and wear only:

1. Seat belts provided for rear or side facing seats;
2. Disabled person's belts which are permanently attached to the vehicle;
3. Child restraints which are permanently attached to the vehicle;
4. Obligatory seat belts as specified above.

No check is required for disabled person's belts or child restraints which are not permanently attached to the vehicle.

It will be necessary to ask the operator to remove seat cushions and to open any access flap or luggage locker door, which was designed to be capable of being readily opened, to allow as much as possible of the seat belt installation to be seen. Some parts of the installation may only be visible with the vehicle on a pit or hoist.

Where a vehicle is fitted with a type approved belt installation it will not be necessary to carry out an installation check. These belts are at present only likely to be fitted to buses with factory installed belts. Details of the vehicles which are fitted with type approved seat belts are shown at the end of this section.

The seats and seat frames should be checked for security and damage. The seat belt anchorages should be checked for security.

If an operator has been provided with documentary evidence to show that a seat belt installation complies with type approval standards (but has not been fully type approved) or that is traceable to an installation tested and shown to meet the requirements of ECE Regulation 14 or Community Directive 76/115 it should be produced at the time to test. It should show registration number or chassis number of the vehicle and the name and address of the installer. It should also show the test number and the date and location of the test of the installation. Original certificates are required. Photocopies are not acceptable. Presentation of the certificate would not replace the need for the examination



where a 'stepped washer' or collar is used to eliminate the excessive clearance and a suitable washer is fitted between the bolt head and the anchorage to prevent the bolt pulling through. The use of smaller bolts, self tapping screws or wood screws is not acceptable.

- e. It is not acceptable to drill tubular seat frames to allow belts to be bolted to the frame except in the cases where a manufacturer has approved the installation and the operator presents a certificate issued by the manufacturer or his agent declaring that the installation is satisfactory.
- f. Clamp type brackets are acceptable provided that they are properly secured (see Diagram 2).
- g. On seats constructed with a wooden frame it is unacceptable to mount the belts either directly to the frame or to a metal base which is attached to the frame only by wood screws. Unless there are additional reinforcement brackets fitted that provide a direct load path to the seat leg and side mounting the installation would be rejected. This reinforcement could take the form of steel angle sections or plates, alternative materials may be used provided that they are of comparable strength (see Diagrams 3 & 4 for details of a typical installation).
- h. Where seat belts are attached to thin sheet metal seat frames the bolts anchoring the belt must be of the minimum dimensions shown in paragraph D and must be adequately supported by the use of load spreading washers between the frame and the nut. Typically this would be 25mm in diameter and 2mm thick. If two belts are attached at the same point with a single bolt then a larger reinforcement plate 35mm diameter x 3 mm thick (or a rectangular plate of minimum dimensions 21 x 46 x 3mm) must be used. The sizes quoted are for steel reinforcement plates, alternative materials may be used but must provide comparable strength.
- i. Where seat belts are fitted to the rear seats of a vehicle check the anchorage to ensure that it is not anchored solely to the thin metal sheet which separates the boot area from the passenger compartment. It is essential that seat belt anchorages are secured to a strong cross member connected to the structural members of the vehicle. The connection should be to such a standard that there is confidence that it will be able to transfer the seat belt loads into the structure of the vehicle. This may involve the fabrication of an additional framework at the rear of the vehicle. An example of typical reinforcement of this area would be by the use of additional square section tubing 40 x 40 x 3 mm, or angle plate 50 x 50 x 4 mm across the full width of the vehicle. The sizes quoted are for steel reinforcement, alternative materials may be used but must provide comparable strength. A full width reinforcement that is only attached to the thin metal sheet is unacceptable and would be a reason for failure.
- j. Three point belts will only be accepted under the following circumstances:  
  
If the seat utilises tubular frames or tubular 'H' pattern legs:
  - The seats have been reinforced as detailed in Paragraph K or

- A purpose built structure to which belts are attached is fitted to the vehicle, an example is shown in Diagram 5. Alternatively the belts may be attached to solid bodywork.

OR

If purpose made seats designed with integral three point belts as standard have been fitted.

- k. Where seats that are permanently mounted in the vehicle have been fitted with lap belts or 3 point belts integral to the seat, then, if the seat utilises tubular frames or tubular 'H' pattern legs it must be reinforced. This will include welding metal buttresses, of similar thickness material as the foot, between the foot and the leg (see diagram 6). Also the welding of a diagonal brace, either in compression or tension between the foot and the seat base attachment of each leg. Alternatively documentary evidence of compliance with Directive 76/115 or ECE Regulation 14 can be presented.

On quick release seats where the feet are mounted directly to tracking by a coupling it may not be practical to weld a buttress to the leg or a diagonal brace to the foot due to the presence of the coupling (see diagram 7).

The coupling would prevent any reinforcement being placed in an effective position, also the coupling could be damaged if welding occurred close to it. On this type of installation the belts can be attached directly to the tracking with quick release mounts or the legs should be modified to use an alternative method of attachment to the tracking.

On seats where the feet are mounted to a metal bar or tube which is then connected to tracking by a quick release coupling, then the seat has to be reinforced with buttresses and diagonal brace as detailed above.

On vehicles with floor mounted seat belts where the belt is anchored close to the seat mounting bolt then the rear foot of each leg must be buttressed to the leg.

- l. If lap belts are fitted and there is the possibility of passengers hitting their heads on any harsh object such as a grab rail or seat stanchion, padding or other suitable protection must be provided on these objects. The protection does not need to cover the full length of a seat grab rail but should cover a length of at least 300mm directly in front of each passenger. Padding must be compressible and of a depth of at least 50mm, measured to the surface of the bar and not compress more than 25mm under reasonable thumb pressure, or 25mm thick and not compress more than 5mm. Ordinary seat foam or pipe lagging foam is unlikely to be of sufficient density for this purpose.
- m. Lower anchorages should be at least 320mm apart. This need not be the distance between the anchorage points of the belt but it can be between two structural parts of the seat that the belt is routed round. If the measurement is between mounting bolts it should be measured between both centres. Check that the belt will not raise or significantly compress the seat cushion when subjected to a load. There will always be a small amount of compression which is acceptable.

- n. Where belts are attached directly to a metal floor a load spreading washer must be used between the nut and the floor. The bolts must be at least the sizes specified in paragraph D. Typically this washer would be 25mm in diameter and 2mm thick. If two belts are attached at the same point with a single bolt then a larger reinforcement plate of minimum dimensions 35mm diameter x 3 mm thick (or a rectangular plate of minimum dimensions 21 x 46 x mm) must be used. The sizes quoted are for steel reinforcement plates, alternative materials may be used but must provide comparable strength. Reinforcement plates should follow, as far as practicable, any contours in the floor to which they are attached.
- o. Where a belt is attached directly to a wooden floor each anchorage must be reinforced with a plate of minimum dimensions 35 mm diameter x 3 mm thick (or a rectangular plate of minimum dimensions 21 x 46 x 3 mm). If two belts are attached at the same point with a single bolt then the reinforcement plate must have minimum dimensions of 92 mm diameter x 3 mm thick (or a rectangular plate of minimum dimensions 65 x 100 x 3 mm). If two belts are attached in close proximity to each other, then a single reinforcement plate of minimum dimensions of 92 mm diameter x 3 mm thick (or a rectangular plate of minimum dimensions 65 x 100 x 3 mm) should be used ensuring that the bolt holes are not too close to the plate edge. Alternatively two steel reinforcement plates may be used, but they must be of minimum dimensions 52 mm diameter x 3 mm thick (or a rectangular plate of minimum dimensions 46 x 46 x 3 mm). The sizes quoted are for steel reinforcement plates, alternative materials may be used but must provide comparable strength. Reinforcement plates should follow, as far as practicable, any contours in the floor to which they are attached.
- p. Where mounting rails designed for the adjustment of seat pitch are fitted and utilise an angled claw type clamp (see Diagram 8) with a clamping face of less than 15 mm wide it is not acceptable for a seat on which a belt is mounted to be merely clamped to the rail. The clamp to the rear foot of each leg must be modified by fitting a bolt through the claw fitting, the rail, floor and a suitable structure member (as in most vehicles). The bolts must have appropriately sized load spreading washers fitted beneath the bolt head and underneath the retaining nut. A single bolt should be not less than 8 mm (5/16") diameter. Any alternative to this is only acceptable if documentary evidence is provided.
- q. Parallel type claw fittings, for a seat on which a belt is mounted, will be considered satisfactory provided that the securing bolts are fully tightened. (See Diagram 9).
- r. If a seat, on which a belt is mounted, is bolted to a flat rail the bolts must pass through the leg, rail, floor and a suitable structure member.
- s. It is acceptable for seats to be attached to a purpose built tracking (e.g. keyhole, 'T' slot) designed for securing seats and wheel chairs, providing the tracking is securely attached to the vehicle structure with bolts or fasteners in all the retaining holes or marks provided by the manufacturers.
- t. It is unacceptable to fit seats, with seat belts, directly to unsupported wooden floors unless additional reinforcement is provided. This will involve the fitting of steel reinforcement plates of minimum dimensions 92 mm diameter x 3 mm thick (or a

rectangular plate of minimum dimensions 65 x 100 x 3 mm), between the underside of the floor and the securing nut below the floor of the rear leg and between the leg and between and the top side of the floor of the front leg. If the area of the foot of the front leg is greater than 65 x 100 mm, then the front reinforcement plate is unnecessary.

- u. A 'looped' type seat belt fitting is acceptable provided it is not free to float along any part of the seat structure. Any free movement in excess of 25 mm is a reason for failure.
- v. The upper anchorage point should be at least 475 mm above the height of an uncompressed seat cushion. This dimension is to be measured parallel to the backrest. The upper anchorage point should be a minimum of 110 mm from the centre line of the seat back to the side of the seat.
- w. A lap belt or the lap section of a 3 point belt must be positioned to lie across the wearer's pelvis and not the stomach. This is to reduce the risk of abdominal injury and to prevent 'submarining'. In practice this may result in the belt lying across the top quarter of the thigh.
- x. Seat belt components should not be fitted to seats in such a way that they significantly intrude into the gangway space and are likely to cause injury to passengers either by tripping or by hitting the component.

There may be occasions when carrying out the condition check, on a vehicle which had an installation check on a previous test, that obvious defects are found in an installation item. This will be a reason for failure.

## **EXEMPT VEHICLES**

Ford Transits with type approved seat belt installations can be identified as follows.

- 12, 14, 15, 16 and 17 seat (including the driver) Transits manufactured after 1 October 1991 where the fourth character of the VIN Number is 'E'.
- 17 seat (including the driver) Transits where there is a six figure code EJA \*CL or EJJ \*CL marked in the box on the top right hand of the manufacturer's plate (in the type code box). In the code the fourth digit marked \* may be any character.

LDV 200 and 400 series models with type approved seat belt installations can be identified as follows.

- Chassis number from 933478 onwards and the seventh character of the VIN number is 'S'.

LDV Pilot and Convoy models with type approved seat belt installations can be identified as follows.

- Chassis number from 000001 onwards and the seventh character of the VIN number is 'S', 'X' or 'Z'.

LDV Maxus models with type approved seat belt installations can be identified as follows.

- The 7<sup>th</sup> digit of the VIN number is either a '6' or 'X'.

Mellor bodied Renault Masters which have been issued with a PSV Certificate of Conformity in GB in place of a Certificate of Initial Fitness.

Berkhof bodied coaches – Excellence 3000, Axial 30, 50 and 70 and Radial model coaches with body numbers from 2852 onwards.

**IMPORTANT NOTE: TO BE EXEMPT FROM THE CHECK, VEHICLES MUST HAVE BEEN FITTED WITH THE SEAT BELT INSTALLATION BY THE VEHICLE MANUFACTURER WHEN NEW. IF YOU ARE AWARE THAT A VEHICLE WITH A CHASSIS NUMBER SHOWN ABOVE HAS HAD ANY SEATS/SEAT BELTS FITTED BY ANY OTHER INSTALLER, EG, WHERE IT HAS BEEN ADAPTED TO CARRY WHEELCHAIRS AND HAS REMOVABLE SEATS ON TRACKING, IT WILL NOT BE EXEMPT AND WILL REQUIRE AN INSTALLATION CHECK.**

## **SUPPLEMENTAL RESTRAINT SYSTEMS**

The SRS malfunction indicator lamp (MIL) may display a symbol similar to that shown below, or one depicting a person wearing a seat belt. Alternatively, the letters SRS or another symbol may be displayed.



## **REASONS FOR FAILURE**

	Deficiency Category
1. Obligatory Seat Belt (see Table)	
a. Missing;	MAJOR
b. Of an incorrect type;	MAJOR

2. Anchorages:
  - a. With excessive corrosion, serious deterioration or a fracture in a load bearing member of the vehicle structure within 300 mm of the anchorage. (Where a seat belt is attached to a seat frame this will apply to all seat mounting points); MAJOR
  - b. With excessive corrosion, serious deterioration or a fracture in a load bearing member of the vehicle structure within 300 mm of the anchorage. (Where a seat belt is attached to a seat frame this will apply to all seat mounting points) and is likely to detach DANGEROUS
  - c. A seat belt not securely fixed to the seat or the vehicle structure; MAJOR
  - d. Missing. MAJOR
  
3. Locking Mechanism, Stalks, Retracting Mechanism and Fittings:
  - a. Locking mechanism of a seat belt does not secure or release as intended; MAJOR
  - b. An attachment or adjustment fitting fractured, badly deteriorated or not operating effectively; MAJOR
  - c. Corrosion or deterioration of a flexible stalk likely to lead to failure under load; MAJOR
  - d. Broken flexible stalk strands; MAJOR
  - e. A retracting mechanism that does not retract the webbing sufficiently to remove all of the slack from the belt with the locking mechanism fastened and the seat unoccupied. MAJOR
  
4. Condition of Webbing:
  - a. A cut which causes the fibres to separate; MAJOR
  - b. Fluffing or fraying not sufficient to obstruct correct operation of the belt or which has not weakened the webbing; MINOR

- |  |  |           |
|--|--|-----------|
| c.   | A cut or damage or fluffing or fraying sufficient to obstruct correct operation of the belt or which has clearly weakened the webbing; | MAJOR     |
| d.   | Stitching badly frayed, insecure, incomplete or repaired.  | MAJOR     |
| 5. Seat Belt Fittings:   |  |           |
| a.   | Any guide, stalk or pivot with obvious signs of structural weakness such that failure is likely.                                       | MAJOR     |
| 6. Seat or seats to which seat belts are attached:   |  |           |
| a.   | Insecure;  | DANGEROUS |
| b.   | With a cracked or fractured leg or frame.  | MAJOR     |
| 7.   | An airbag obviously missing or defective.  | MAJOR     |
| 8. A Supplementary Restraint Systems (SRS) malfunction indicator lamp indicating a system malfunction. |  |           |
| a.   | A seat belt load limiter or pretensioner obviously missing where fitted as original equipment  | MAJOR     |
| b.   | a seat belt pretensioner or a 'folded webbing' type load limiter obviously deployed.   | MAJOR     |
| 9. 9. Installation defect found on annual test:  |  |           |
| a.   | Any obvious installation defect found during the inspection.   | MAJOR     |
| 10. 10. Installation inspection:   |  |           |
| a.   | Evidence that original webbing has been cut and/or reworked, (e.g. belts knotted, fraying or fluffing removed/sealed by burning etc);  | MAJOR     |
| b.   | Any part of the installation which has a sharp edge which could or is likely to cut or abrade the webbing.                             | MAJOR     |
| c.   | A directly attached anchorage not secured by   | MAJOR     |

	standard seat belt mounting bolts and washers as detailed in paragraph D;	
d.	An anchorage insecure;	MAJOR
e.	A tubular seat frame that has been drilled for the purpose of attaching a seat belt;	MAJOR
f.	A directly attached anchorage not attached to a load bearing member or without suitable reinforcement;	MAJOR
g.	Retro-fitted three point belt which is not mounted on a suitable structure.	MAJOR
h.	Tubular frame legs or tubular 'H' pattern legs which have not been reinforced with buttressing and diagonal bracing, or buttressing where a floor mounted belt is fitted close to a seat leg.	MAJOR
i.	Belt fitted to a seat which has not been suitably reinforced or modified;	MAJOR
j.	Without suitable padding as detailed in paragraph I;	MAJOR
k.	Lower anchorages less than 320 mm apart;	MAJOR
l.	In such a position that loading the belt causes the cushion to be raised or significantly compressed thus allowing the occupant to effectively move forward;	MAJOR
m.	An anchorage attached to the floor without reinforcement plates of a suitable size and contour;	MAJOR
n.	With load spreading washer(s) missing from anchorage bolt;	MAJOR
o.	Claw type seat mounting with inadequate means of securing claw;	MAJOR
p.	On a seat fitted to a flat rail the bolt does not pass through the leg, rail, floor and a suitable structural member or the floor has not been suitably reinforced;	MAJOR
q.	Tracking for securing seats and wheelchairs insecure;	MAJOR
r.	Free movement for a looped belt more than 25 mm at the anchorage;	MAJOR
s.	Upper anchorage of three point belt less than 475	MAJOR

- mm above uncompressed seat cushion measured parallel to the seat back;
- t. Upper anchorage of three point belt(s) less than 110 mm from centre line of seat; MAJOR
  - u. Incorrect positioning of a lap belt or lap section of a three point belt, i.e. the belt lies across the stomach or forward of the top quarter of the thigh; MAJOR
  - v. A seat belt component fitted to a seat significantly intrudes into a gangway and is likely to cause injury to a passenger. MAJOR
  - w. For vehicles subject to enhanced seat belt requirements no evidence that seat belt anchorages are likely to meet the strength requirements of EC Directive 76/115/EC as amended by Directive 96/38/EC. MAJOR

Typical Methods of Attaching Seat belts

Diagram 1

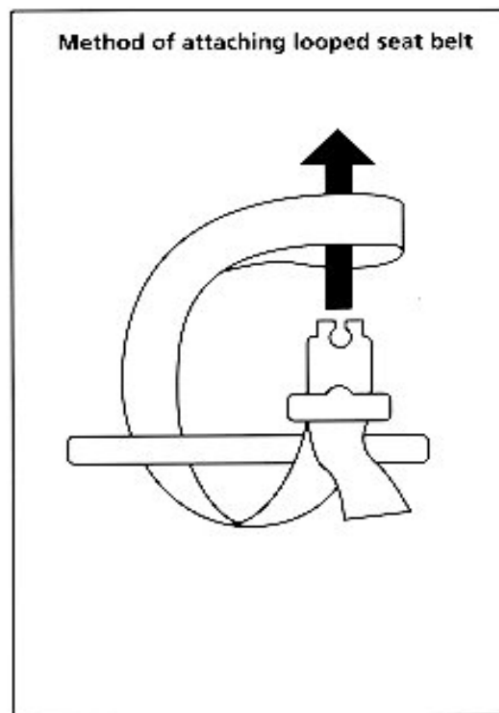
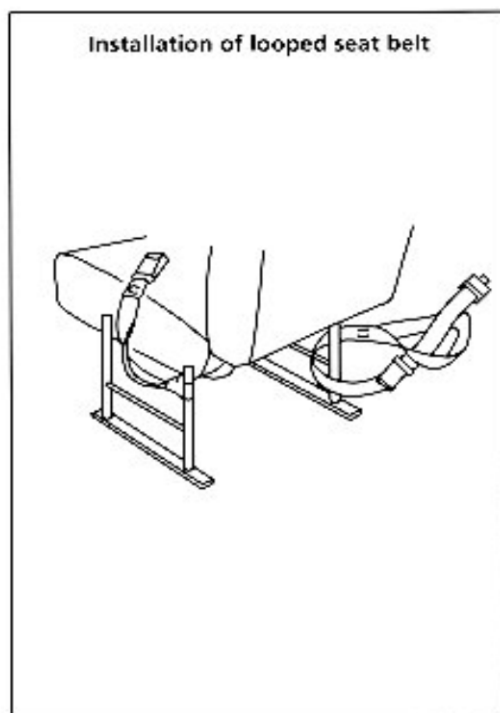
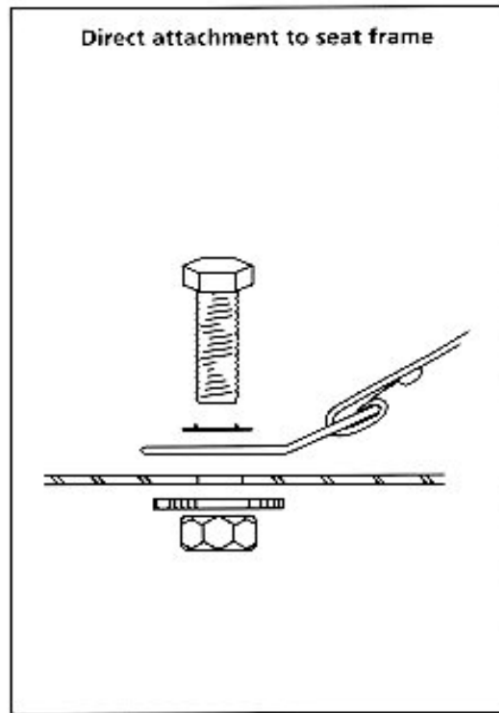
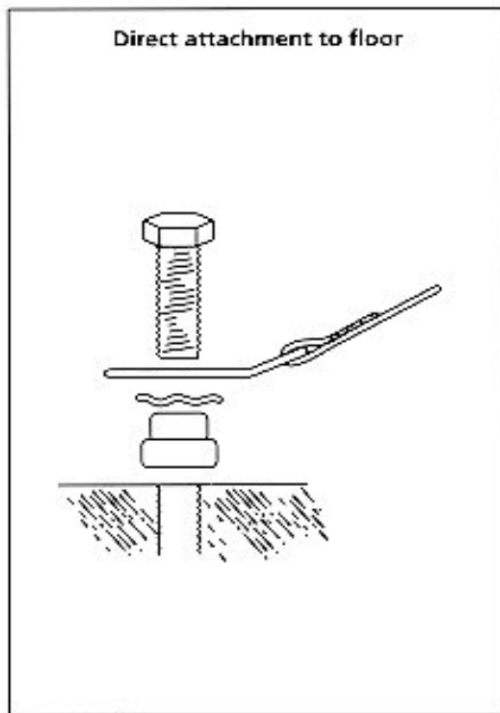

Example of a typical clamp bracket

Diagram 2

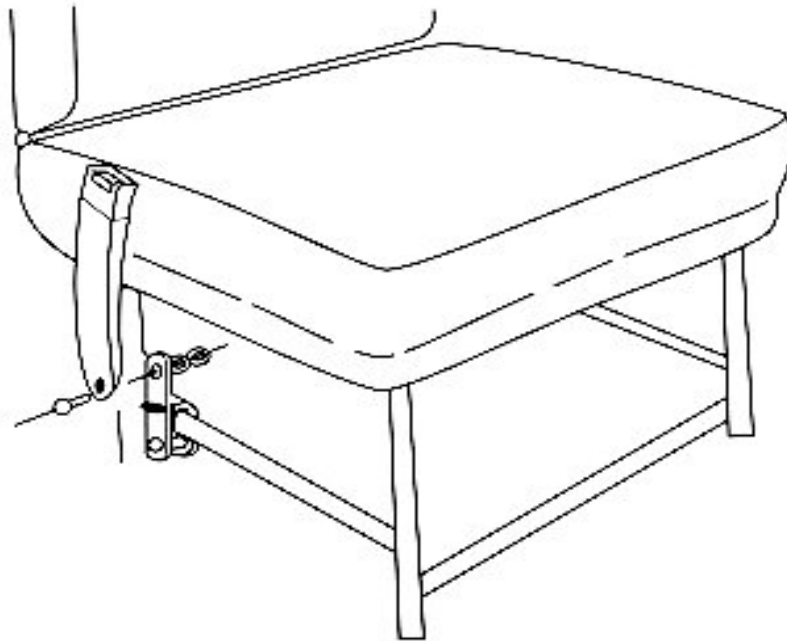

Wooden framed seats with a metal base - rear view

Diagram 3

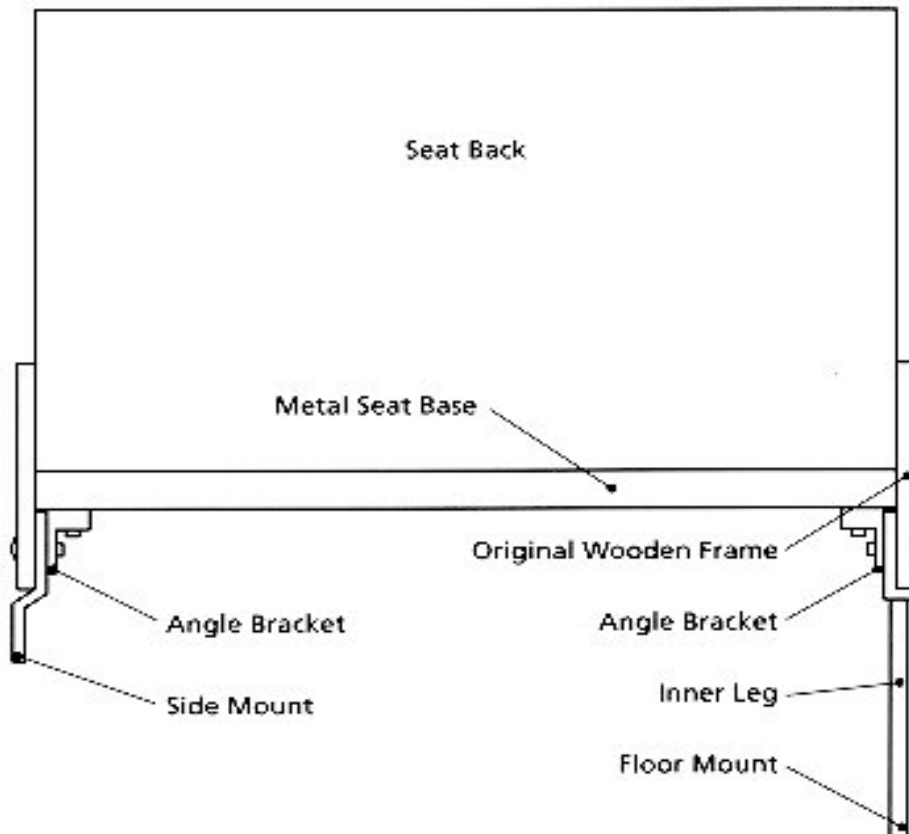

Diagram 4

Wooden framed seats with a metal base - Enlargement of Reinforcement

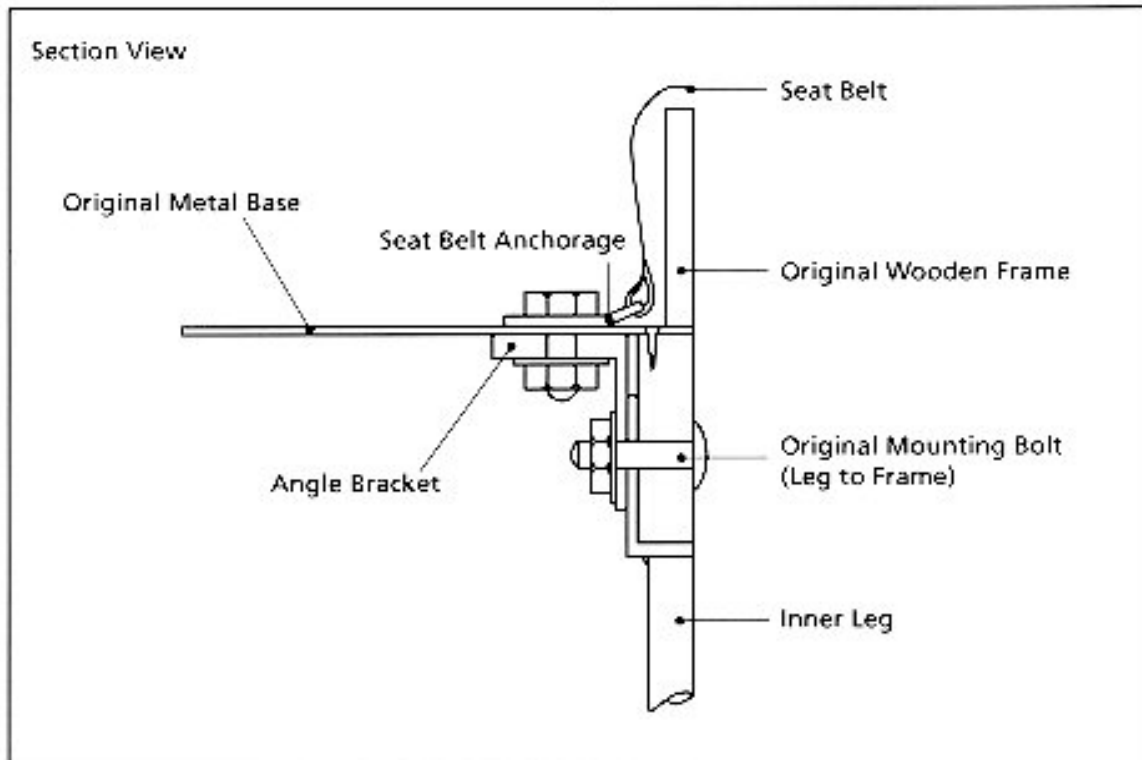

Diagram 5

Example of Additional Structure for Support of Upper Anchorage Points

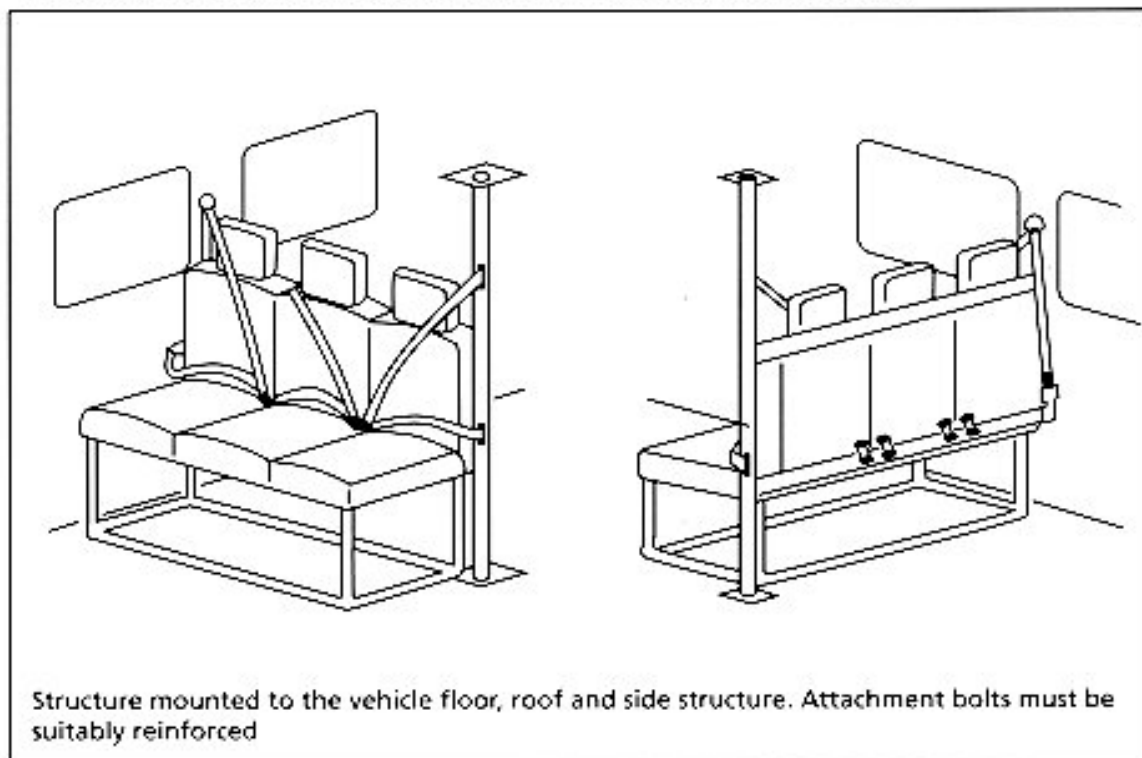
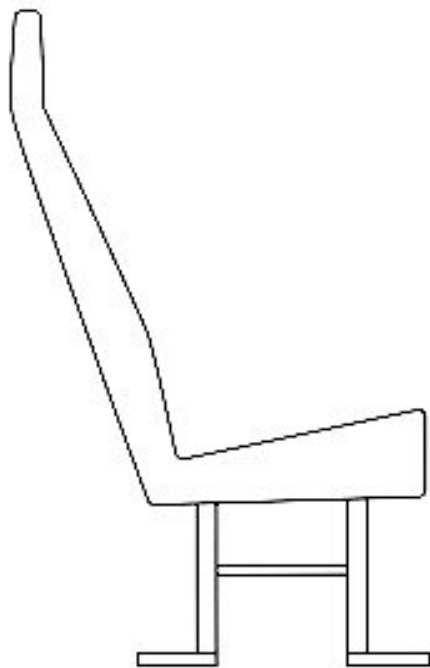
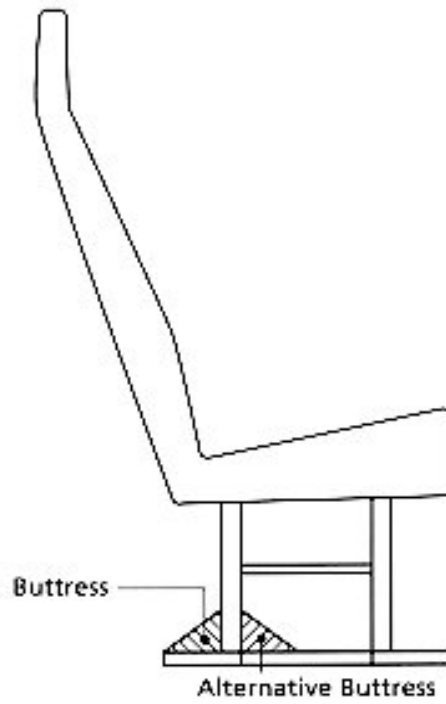

Diagram 6

Typical Minibus seat with standard "H" leg



Minibus seat with buttress to "H" leg



Typical example of diagonal brace

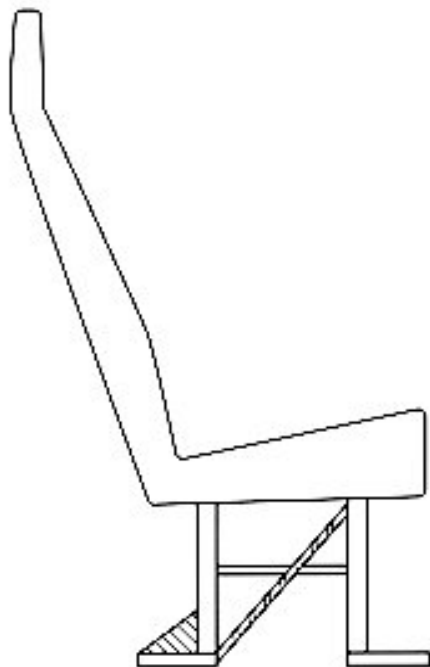

Alternative example of diagonal brace

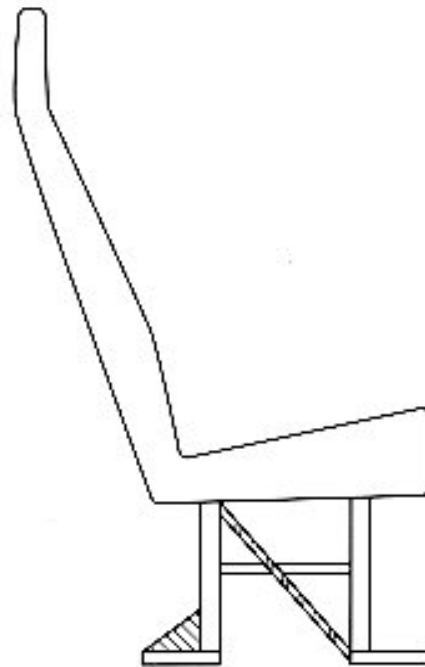

Example of quick release seats that may not be suitable for reinforcement

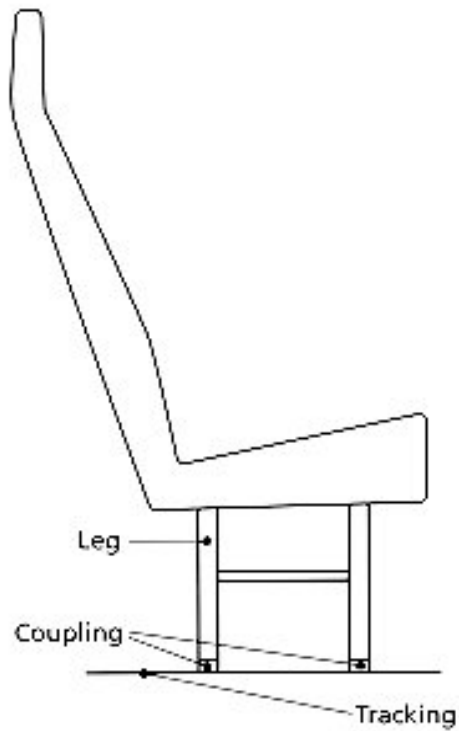

Feet connected directly to tracking.

Example of quick release seat that is suitable for reinforcement

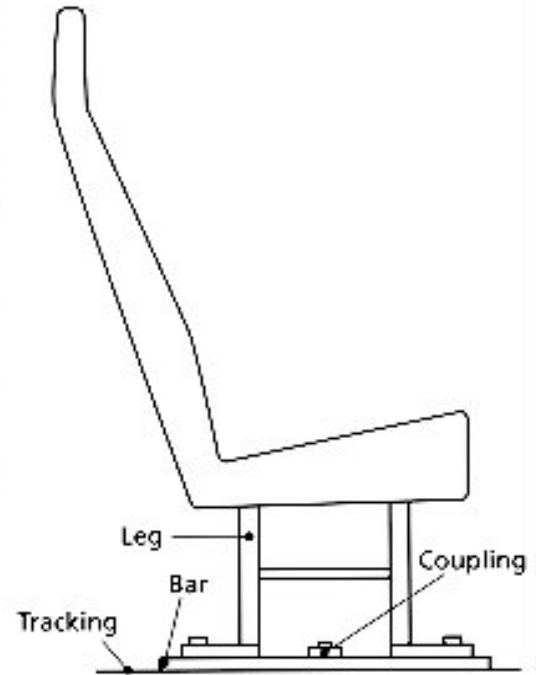

Feet bolted to bar or tube. Quick release mechanism mounted to bar or tube.

Typical Angled Claw Fitting

Diagram 8

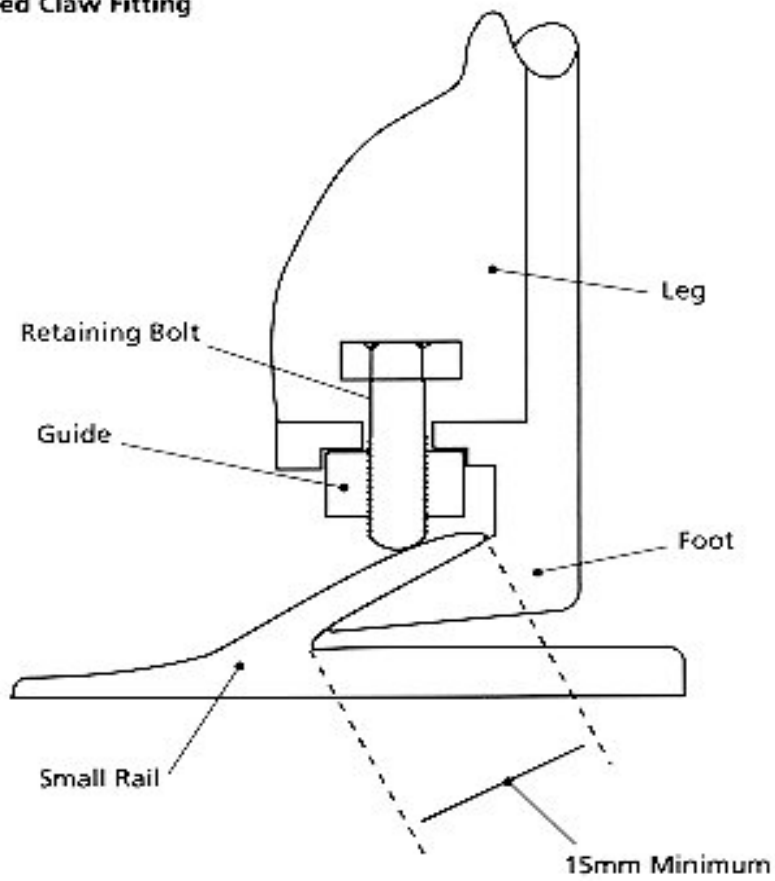

Typical Parallel Claw Fitting

Diagram 9

