

ROAD WHEELS AND HUBS

APPLICATION

This inspection applies to all road wheels and hubs apart from spare wheels.

PROCEDURE AND STANDARDS

- Check all road wheels for carrying capacity, and road wheels, fixings and hubs for condition and security. A nut or stud is considered to be "loose" if it is not obviously carrying out its function of clamping the wheel to the hub/wheel flange.

A 'wheel flange' is a component which is positioned between the road wheel and the hub which contains the wheel studs.

Evidence such as rust marks or elongation of bolt/stud holes must also be taken into account.

- With some vehicles it is not possible to see the road wheels completely from ground level, especially with twin wheels and where the body hides part of the wheels. In such cases the vehicle must be:-

Moved to expose hidden parts of the wheels, or examined from underneath

Whenever possible, presenters should remove wheel embellishers if they prevent a full examination.

Capacity Limitations of 11.75 x 22.5 Alcoa Aluminium Wheels

Wheels with the part number 813520/813523 may be stamped on the inside of the wheel, opposite the valve, with a maximum load rating of 4250 kg or 4500 kg and those with part number 813530/813533 with a rating of 4500 kg.

It has been agreed that wheels with these part numbers and maximum load ratings are suitable for a maximum axle weight of 9150 kg.

Capacity limitations of a wheel marked with a load index.

If a wheel is marked with a load index which indicates that the maximum load is lower than is required to support the axle load, the vehicle should be issued a notice of refusal.

Wheels not marked with a load index or load marking must be assumed to be capable of carrying the axle weight.

COMPATIBILITY OF WHEEL FIXINGS

- Vehicles with conical wheel fixings **MUST NOT** be fitted with wheels from vehicles designed for use with spherical fixings. (British built vehicles normally have conical wheel fixings).
- Vehicles with spherical wheel fixings **MUST NOT** be fitted with wheels from vehicles which are designed for use with conical fixings.
- Volvo wheels of the original spigot-mounting design **WILL NOT** interchange with another type. Volvo wheels designed for later type spigot mounting may be used in an emergency on British built trailers.
- Wheels with conical fixings **MUST NOT** be used on Volvo vehicles because they do not have a machine centre bore to fit hub.
-
- Spigots must extend to the outer wheel centre where twin wheels are fitted.

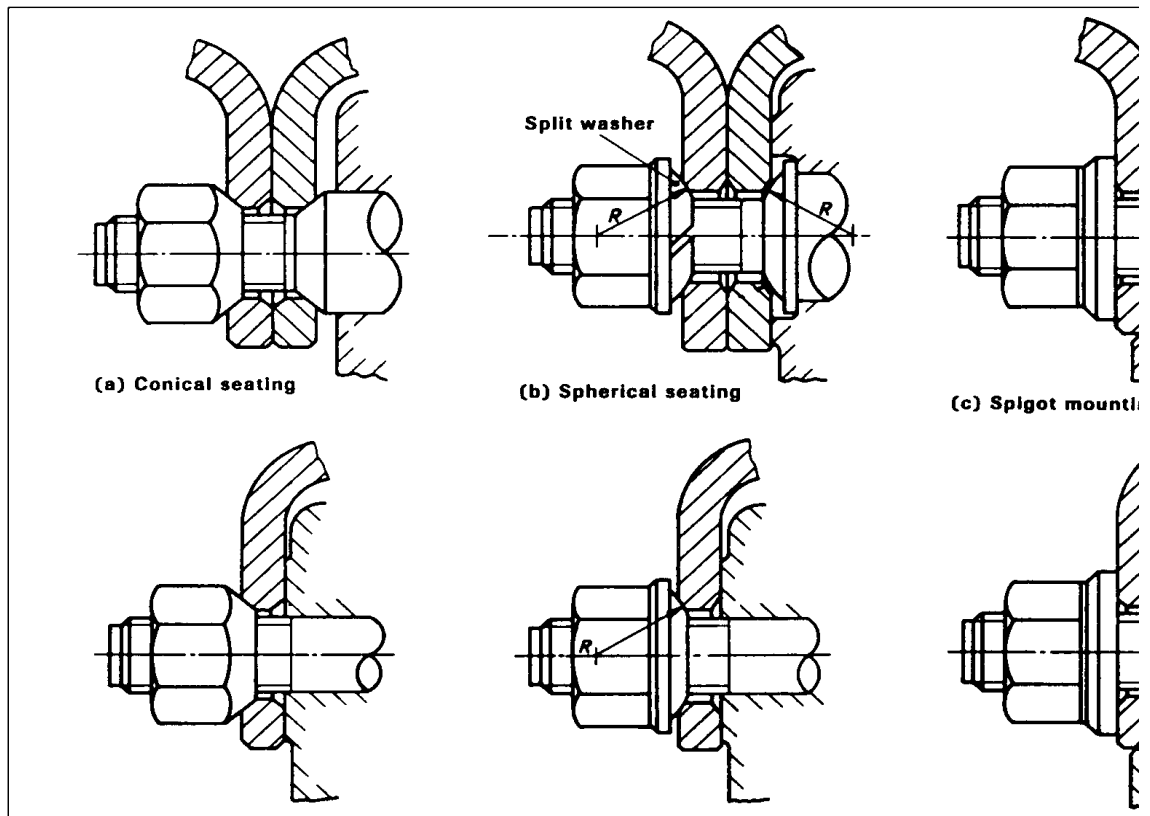

Sleeved two piece flange nut fixing, this fixing method of utilising a sleeved nut has been adopted primarily to allow the retro fitting of aluminium wheels which incorporate a thicker flange.

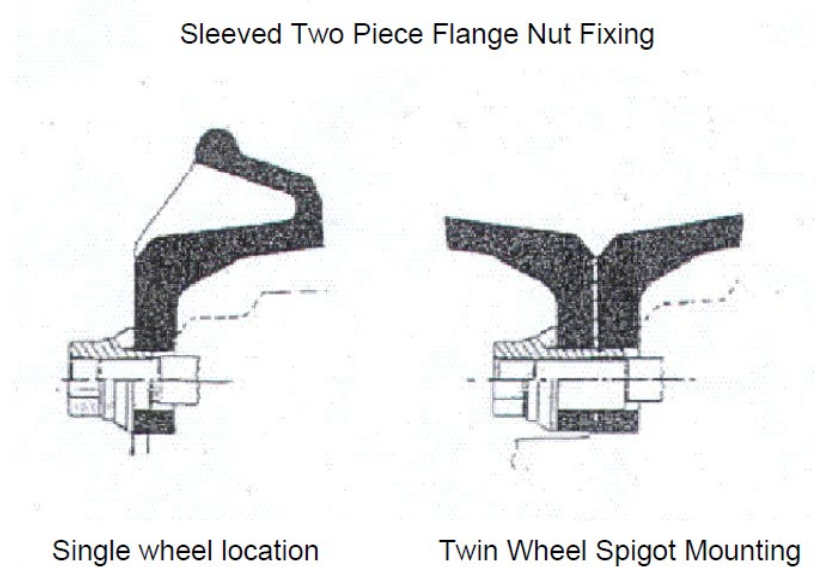

Where wheel trim brackets are secured by the wheel retaining nuts it is acceptable provided the bracket does not stop the wheel nut from seating correctly in the taper of the stud hole. For spigot mounted wheels there may be some overlap between the washer and bracket, failure will only be justified where the nut clamping force is obviously ineffective.

When assessing corroded road wheels, the effects on any wheel stud or nut functionality (clamping the wheel to a hub or wheel flange) must be considered.

Some wheel nut studs do not protrude all the way through the wheel nut this is acceptable provided there is no sign of insecurity.

Note: If a wheel trim bracket prevents a wheel nut from seating correctly in the taper of the stud hole the vehicle must be failed under Reason for Failure 2a.

With a spigot mounted wheel provided the bracket is either the same size as the mating face of the retaining nut washer or larger this would be acceptable.

REASONS FOR FAILURE

	Deficiency Category
1. Tyre retaining ring	
a. Fractured or not properly fitted such that detachment is likely (excluding trailers).	DANGEROUS

- | | | |
|------|--|-----------|
| b. | Butting causing the flange to lift more than 1.5 mm from the rim. | MAJOR |
|
 | | |
| 2. | A wheel | |
|
 | | |
| a. | With any visible elongation of a stud hole | MAJOR |
| b. | With any visible elongation of a stud hole where secure fixing of the wheel is affected | DANGEROUS |
| c. | Badly damaged or distorted (including damaged by the corners of a wheel nut cutting into the material of the wheel) | MAJOR |
| d. | Badly damaged or distorted (including damaged by the corners of a wheel nut cutting into the material of the wheel) where secure fixing of the wheel is affected | DANGEROUS |
| e. | And its fixings not compatible | MAJOR |
| f. | Cracked (except at the bridge over the valve), weld breaking away or an inadequate repair | DANGEROUS |
| g. | Made of aluminium alloy repaired by welding | MAJOR |
| h. | With a load rating less than that required to support the maximum permissible (UK) axle load. | MAJOR |
|
 | | |
| 3. | A hub | |
|
 | | |
| a. | Cracked, badly damaged, or with a half shaft bolt or wheel flange, stud or nut loose or missing | MAJOR |
| b. | Cracked, badly damaged, or with a half shaft bolt, or wheel flange bolts, studs or nut loose or missing where secure fixing of the wheel is affected | DANGEROUS |
| c. | With clearance between a spigot mounted wheel and the hub spigots that exceeds 3mm across the diameter. | MAJOR |
| d. | With a wheel nut or stud missing or loose or obviously not fulfilling the function of clamping the wheel to the hub | MAJOR |
| e. | With multiple wheel nuts or studs missing or loose or obviously not fulfilling the function of clamping the wheel to the hub | DANGEROUS |

- f. With a spigot wheel nut washer cracked MAJOR
- g. With a wheel locating spigot or dowel missing MAJOR